



Your Global Flow Control Partner

Series 98 Pneumatic Scotch Yoke Actuator Operation and Maintenance Manual

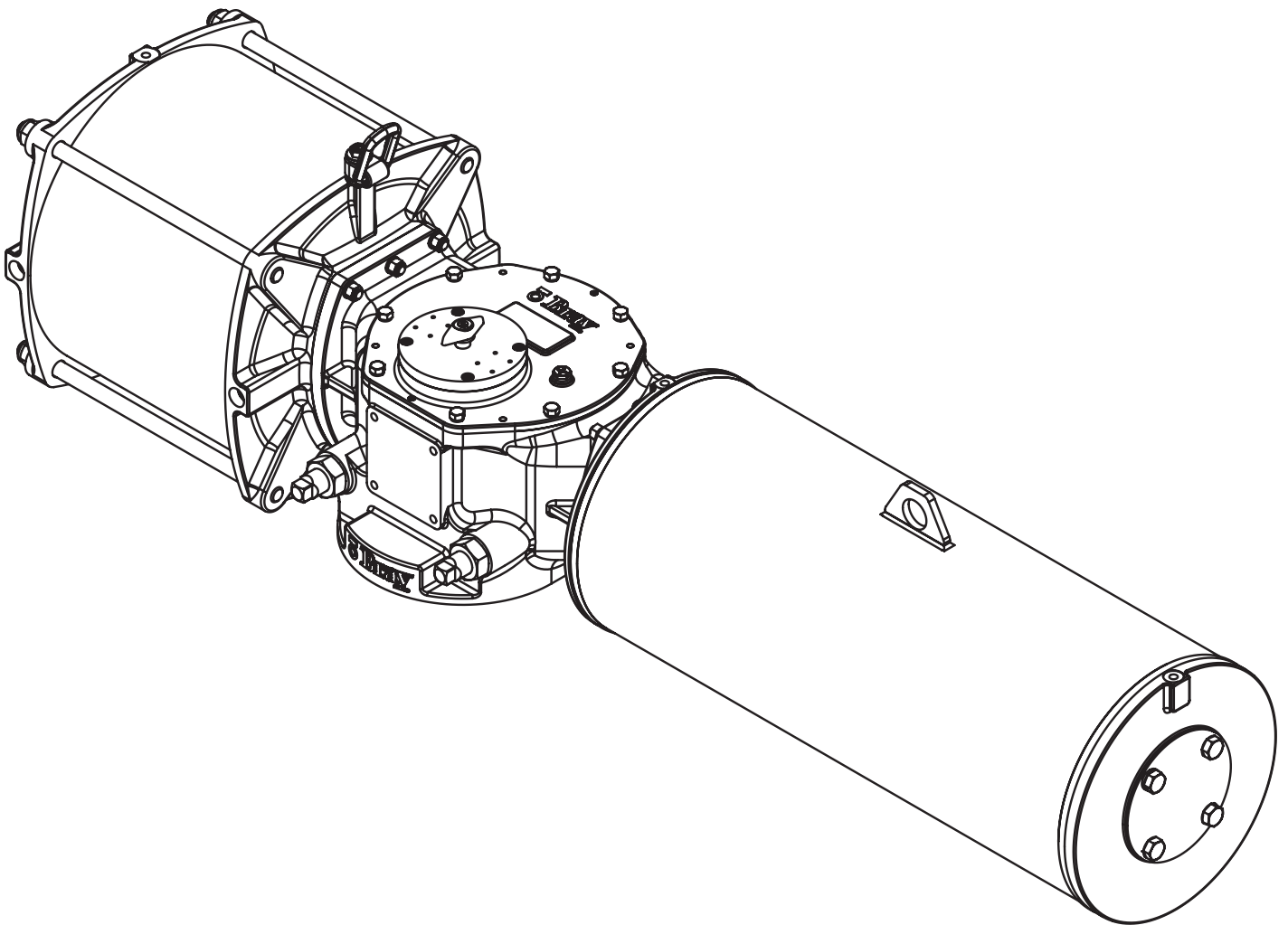

TABLE OF CONTENTS



1.0 - Definition of Terms	3
1.1 Hazard-free Use	3
1.2 Qualified Personnel	3
2.0 Introduction	4
3.0 Installation	4
4.0 Operation Guidelines	5
5.0 Spring Return Pneumatic Actuator Assembly Drawing and Materials of Construction	6
6.0 Maintenance	8
6.1 Lubricants and Maintenance Consumables	8
6.2 Disassembly, Service & Reassembly of Modules	8
6.3 Spring Module	8
6.3.1 Removing the Spring Module	8
6.3.2 Service & Reassembly of the Spring Module	9
6.4 Pressure Module	9
6.4.1 Removing the Pressure Module from Actuator	9
6.4.2 Disassembling the Pressure Module	9
6.4.3 Service & Reassembly of the Pressure Module	10
6.5 Torque Module	11
6.5.1 Disassembling the Torque Module	11
6.5.2 Service & Reassembly of the Torque Module	11
6.6 Reassembly of Actuator	12
7.0 Field Conversions	13
7.1 Fail Safe Condition (for Spring Return Actuators)	13
7.2 Double Acting to Spring Return	13
7.3 Spring Return to Double Acting	13
8.0 Pneumatic Actuator - Double Acting, Single Cylinder Assembly and Materials of Construction	14
9.0 Pneumatic Actuator - Double Acting, Dual Cylinder Assembly and Materials of Construction	16
10.0 Bolting Torques and Tools	18
10.1.a - Pressure Module	18
10.1.b - Pressure Module	18
10.2 - Torque Module	18
10.3 - Spring Module	19
10.4 - Actuator Assembly	19
11.0 Technical Data	20
11.1 - Double Acting Actuators	20
11.2 - Spring Return Actuators	22
12.0 Module Weights	26

13.0 Series 98 Dimensions	27
13.1 Series 98 Dimensions - Bolting pattern	28
13.2 Series 98 Dimensions - Bore	28
14.0 Series 98 General Specifications and Features	29
14.1 Series 98 SEAL KITS AND REPAIR KITS	30
15.0 Hydraulic Override	32
15.1 Installation	32
15.1.1 Installing Hydraulic Override on Spring Return Actuators	32
15.1.2 Operation - Spring Return Hydraulic Override	33
15.2 Installing Hydraulic Override on DA Actuator	33
15.2.1 Operation – DA Hydraulic Override	34
15.3 Maintenance of Hydraulic Override	34
15.3.1 Spring Return Hydraulic Override Cylinder	34
15.3.2 Disassembly of Hydraulic Cylinder	34
15.3.3 Servicing Hydraulic Cylinder	34
15.4 DA Override Cylinder	34
15.4.1 Disassembly of Hydraulic Cylinder	34
15.4.2 Servicing Hydraulic Cylinder	35
15.5 Servicing Hand Pump Unit	35
16.0 Jackscrew Override	36
16.1 Installation	36
16.1.1 Installing DA Jackscrew Override	36
16.1.2 Operating DA Jackscrew Override	37
16.2 Installing SR Jackscrew Override	38
16.2.1 Operating SR Jackscrew Override	38
17.0 Extended Stoppers	39
17.1 Installation	39
17.1.1 Installing Extended Stopper for Torque Module	39
17.1.2 Adjusting Extended Stopper	40
17.2 Installing Extended Stopper for Spring Module	40
17.2.1 Adjusting Extended Stopper	40
18.0 Hydraulic Damper	41
18.1 Assembling the SR Hydraulic Damper Module	41
18.2 Installing the SR Hydraulic Damper Module on S98 actuator	42
Reference Drawings	45
Trouble Shooting Potential Problems	46

Read and Follow These Instructions

Save These Instructions

1.0 - DEFINITION OF TERMS

 WARNING	indicates a potentially hazardous situation which, if not avoided, could result in death or serious injury.
 CAUTION	indicates a potentially hazardous situation which, if not avoided, may result in minor or moderate injury.
NOTICE	used without the safety alert symbol indicates a potential situation which, if not avoided, may result in an undesirable result or state, including property damage.

1.1 Hazard-free Use

This device left the factory in proper condition to be safely installed and operated in a hazard-free manner. The notes and warnings in this document must be observed by the user if this safe condition is to be maintained and hazard-free operation of the device assured.

- Take all necessary precautions to prevent damage due to rough handling, impact, or improper storage. Do not use abrasive compounds to clean, or scrape its surfaces with any objects.
- Configuration and calibration procedures are described in this document. Proper configuration and calibration is required for the safe operation of this product.
- The control system in which the unit is installed must have proper safeguards to prevent injury to personnel, or damage to equipment, should failure of system components occur.
- This document does not cover every detail about every version of the product described. It cannot take into account every potential occurrence in installation, operation, maintenance and use.
- If situations transpire that are not documented in sufficient detail, please request the required information from the Bray Distributor or Representative responsible for your area.

1.2 Qualified Personnel

A qualified person in terms of this document is one who is familiar with the installation, commissioning and operation of the product and who has appropriate qualifications, such as:

- Is trained in the operation and maintenance of pneumatic pressure equipment and systems in accordance with established safety practices.
- Is trained or authorized to energize, de-energize, ground, tag and lock electrical circuits and equipment in accordance with established safety practices.
- Is trained in the proper use and care of personal protective equipment (PPE) in accordance with established safety practices.
- Is trained in first aid.
- In cases where the device is installed in a potentially explosive (hazardous) location – is trained in the operation, commissioning, and maintenance of equipment in hazardous locations.

2.0 INTRODUCTION

The instructions and guidelines in this manual enable competent technicians to install, operate, adjust and carry out routine maintenance activities on Series 98 pneumatic actuators. Responsibility lies with the user to follow the instructions in this and in any additional documentation related to the product and accessories supplied with it.

User shall ensure the equipment is installed and operated in the environment that it is intended for and effective protections are provided against exposure to pressure and temperature in excess of maximum rating. Failing to do so may affect the product warranty. Only trained personnel, aware of precautions in hazardous environments and health and safety in the workplace should service the equipment.

Series 98 Actuators are designed for quarter turn rotary valves, in configurations as:

- DA- Double Acting with a single cylinder
- DD- Double Acting with dual cylinders
- SC- Spring Return Fail Close (CW)
- SO- Spring Return Fail Open (CCW)

Two output torque characteristic profiles are available in the form of Symmetrical Yoke and Canted Yoke.

Standard actuators have a mounting base to ISO 5211. MSS mounting base is available as an option.

Mounting of the shaft driven accessories is per VDE 3845/NAMUR standard.

The maximum operating pressure of the Series 98 Pneumatic Scotch Yoke Actuators range from 40 to 150 psig, depending upon the size and configuration. Refer to the MOP (maximum operating pressure) charts or the name plate on the actuator for the maximum operating pressure.

Operating media shall be clean and dry, in accordance to ISO 8573-1 Class 2.3.4 filtered to 5 microns or better, with pressure dew point of -20°C (-4°F) or at least 10°C (18°F) below ambient temperature.

The user shall plan and implement a periodic maintenance program to ensure the service conditions continue as intended and the actuator is monitored and maintained per manufacturer's recommendations.

3.0 INSTALLATION

The S98 actuators are assembled, tested and delivered per the configuration ordered. The mounting of the actuator may be direct onto the valve or may require a mounting kit that would include a bracket, coupler shaft with keys and hardware.

WARNING

Use appropriate tackles and slings to lift the actuator. Refer to Technical Data table for the approximate actuator weight. The lifting lugs provided are for lifting the actuator only and not for lifting the complete valve-actuator-accessory assembly.

NOTICE

- The user shall ensure installation in intended service conditions and that the actuator is not covered with dirt/dust or other substances that may affect any heat dissipation capability, resulting in exceeding the maximum temperature rating of the actuator.
- To prolong actuator seal life use only permitted media of recommended quality.
- The actuator shall not be installed in hazardous areas incompatible with the defined gas groups and temperature class.
- When using manual override sandwich gearbox, ensure the gearbox has over travel at least equal to that of the actuator.
- The actuators can be mounted on valves in different positions, but care shall be taken to reorient suitably, some accessories like filter regulation units, hydraulic override power pack reservoirs, etc. that are gravity dependent for functioning.

Before proceeding with installation, check compatibility of the valve stem to the actuator bore. The length, size and configurations (keyways / double D / square) must match. Additionally, check compatibility of valve and actuator bolting pattern. If using a mounting kit, physically check the coupler to ensure it fits the actuator bore and the valve stem.

1. Ensure the pressure module is depressurized completely by venting the ports to atmosphere and any power sources to accessories are disconnected.
2. Ensure the valve and actuator are aligned to the same position (i.e., valve closed - actuator closed or both in open). For spring return actuators, align the valve to the fail safe position of the actuator. If a sandwich gearbox manual override is used, then make sure it is also aligned with the valve and actuator position.
3. Secure the valve, bolt the mounting bracket to the valve

and fit the coupler shaft on the valve stem (when using mounting kit). Ensure the actuator's bore and seating face are clean and coat the valve stem/adaptor with a suitable oil/grease. Position the actuator to align the valve stem (or coupler shaft) with the yoke bore and slide the actuator on until the actuator seats on the bracket mounting surface (or on the valve top flange, in case of direct mounting).

4. When using a manual override sandwich gearbox between the actuator and valve, first couple and fix the gearbox on the valve following the gearbox installation procedure. Back off the gearbox travel stop bolts. Mount the actuator on the gearbox with the coupler shaft and bolt up the actuator on the gearbox flange.
5. In order to align the bolt holes, it may be necessary to loosen the valve-bracket bolting slightly. The actuator mounting bolts should easily thread into the actuator base without side loading on the bracket (or the valve top flange). If needed, turn the actuator a bit and/or adjust the actuator travel stops. Bolt up the actuator to the bracket / gearbox flange / valve as the case may be. Refer to the Bolting Torque table for recommended torque values.
6. Before operating the actuator, disengage the manual override, if present. The travel stops of the actuator shall limit the stroke and not those on the gearbox/valve, if present.
7. Adjust the travel stop bolts of the actuator for the proper open and closed valve positions, per valve manufacturer's recommendations. Refer to the Series 98 specifications for the travel adjustment range for different models.
8. Tighten the travel stop bolts lock nuts after adjusting the stop bolts. Ensure the travel stops on gearbox or valve, if provided, are now adjusted and locked to fractionally lag the actuator's stop position.

NOTE: When used for actuating swing disc type of valves, ensure that the stop bolt is sufficiently backed off to permit the valve disc to seat.

9. Ensure the manual overrides are set for the normal pneumatic operation before putting the actuator to test in power operation mode. Refer to Sec. 15 through 17.
10. Stroke the actuator a few times at not more than MOP to check for proper and smooth operation. If the actuator is equipped with a switchbox or other accessories, adjust them at this time.

NOTICE

It is recommended to ground the actuator assembly against any buildup of static electricity.

4.0 OPERATION GUIDELINES

Series 98 actuators operate well in both on-off and modulating applications. The accessories, control elements, tubing and fittings shall be chosen for adequate flow rates so as not to constrict flow or cause high pressure drop affecting the performance of the actuator.

Maximum Operating Pressure (MOP) of the actuator is mentioned on the nameplate and shall not be exceeded. Suitable pressure regulator and safety valve shall be incorporated in the supply line, if the line pressure is higher than this.



CAUTION

Do not pressurize from the cap end port of the spring return actuator. This port is normally fitted with a breather filter. If there is a possibility of the actuator being submerged temporarily in water due to flooding, then this port must be provided with an extension pipe with the breather filter on the pipe end, at a safe height above the water level.

Spring Return actuators work on air stroke or spring stroke by pressurizing or venting respectively, the adaptor side port (rod end side). A 3/2 way valve is typically used.

DA models require alternate ports to be pressurized and vented for stroking. A 5/2 or 5/3 way direction control valve or two 3/2 way valves may be used.

DD models have adaptor ports of the cylinders tubed in parallel with the end cap ports of the other side cylinder. The two cylinders work simultaneously with cap end of one and rod end of the other pressurized, at a time.

Actuator Mounting Bolt Torque

Bolt size	Torque	
	Nm	Lb-in
M8	30	265
M12	110	975
M16	260	2300
M20	510	4515
M30	1550	13720
M36	2500	22125

5.0 Spring Return Pneumatic Actuator Assembly Drawing and Materials of Construction

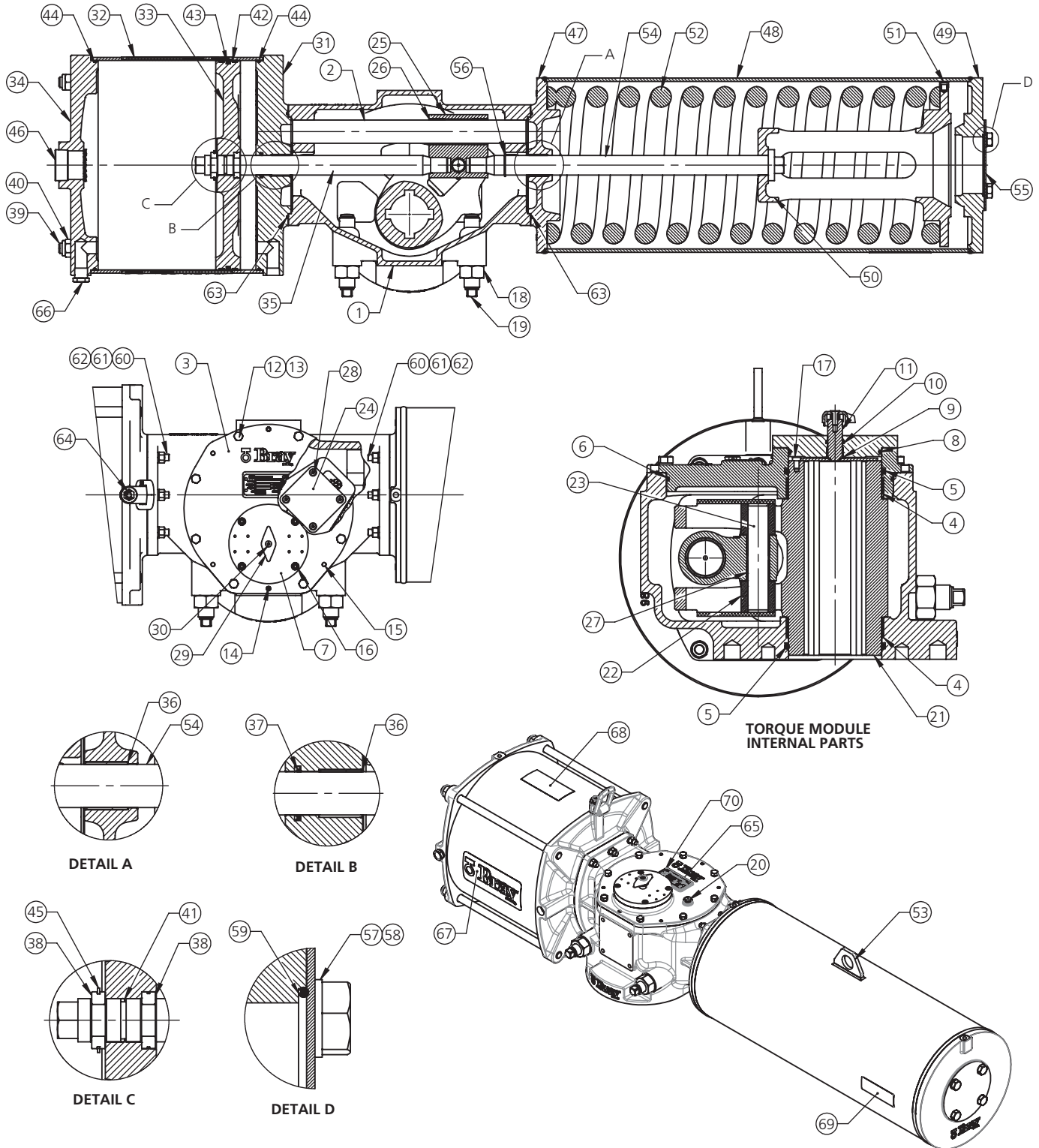

For reference only. Please refer to current revision of ES-00019 drawing for more information.

ITEM	DESCRIPTION	MATERIAL	QTY.
1	Yoke Housing	Ductile Iron	1
2	Guide Rod	Alloy Steel	1
3	Housing Cover	Ductile Iron	1
4	** Bushing (Yoke)	PTFE Bronze	2
5	* O-ring (Yoke)	Buna-n	2
6	* O-ring (Cover)	Buna-n	1
7	Top Cover	Ductile Iron	1
8	* O-ring (Top Cover)	Buna-n	1
9	** Flanged Bushing	PTFE Bronze	1
10	* O-ring (Accessory Drive)	Buna-n	1
11	Accessory Drive	Stainless Steel	1
12	Hex Bolt	Steel	8
13	Spring Washer	Spring Steel	8
14	Set Screw, Socket Head	Steel	2
15	Dowel Pin	Hardened Steel	4
16	Socket Head Caps Screw	Steel	4
17	Socket Head Caps Screw, Low Head	Steel	1
18	Seal Nut	Steel	2
19	Stop Bolt	Steel	2
20	Breather Vents	Carbon Steel	1
21	Yoke	Ductile Iron	1
22	** Slider Block	Bronze	2
23	Yoke Pin	Alloy Steel	1
24	Retainer Plate	Plastic	2
25	Guide Block	Carbon Steel	1
26	** Bushing (Guide Rod)	PTFE Bronze	2
27	** Bushing (Yoke Pin)	PTFE Bronze	2
28	Cap Screw, Flat Head, Hex Socket	Steel	8
29	Position Indicator	Plastic	1
30	Cap Screw, Flat Head, Hex Socket	Steel	1
31	Adaptor, Pressure Module	Ductile Iron	1
32	Barrel	Carbon Steel	1
33	Piston	Ductile Iron	1
34	End Cap, Pressure Module	Ductile Iron	1
35	Piston Rod	Alloy Steel	1

ITEM	DESCRIPTION	MATERIAL	QTY.
36	** Bushing (Adaptor)	PTFE Bronze	2
37	* Seal, U-cup	Buna-n	1
38	Split Collar	Alloy Steel	4
39	Tie Rod	Steel	4
40	Locknut, Nylok	Steel	4
41	* O-ring (Piston Rod)	Buna-n	1
42	* Wear Ring	Ptfe	2
43	* Quad Seal	Buna-n	1
44	* O-ring (Barrel)	Buna-n	2
45	Retainer Ring	Stainless Steel	1
46	Pipe Plug	Carbon Steel	1
47	Adaptor, Spring Module	Carbon Steel	1
48	Pipe	Carbon Steel	1
49	End Cap, Spring Module	Carbon Steel	1
50	Spring Guide	Carbon Steel	1
51	Button	Plastic	9
52	Spring, Compression	Alloy Steel	1
53	Lifting Lug	Carbon Steel	1
54	Spring Rod	Alloy Steel	1
55	End Cover	Carbon Steel	1
56	Retainer Ring	Stainless Steel	1
57	Spring Washer	Spring Steel	4
58	Hex Bolt	Steel	4
59	* O-ring (End Cover)	Buna-n	1
60	Stud	Steel	12
61	Nut	Steel	12
62	Spring Washer	Spring Steel	12
63	* O-ring (Module)	Buna-n	2
64	Lifting Eye Bolt	Carbon Steel	1
65	Name Plate	Stainless Steel	1
66	Breather Vent	Stainless Steel	1
67	Label, Logo	Metallized Polyester	2
68	Label, Configuration	Metallized Polyester	1
69	Label, Caution	Metallized Polyester	1
70	Rivets	Stainless Steel	4

*	Parts in Seal Kits
* & **	Parts in Repair Kits

For reference only. Please refer to current revision of ES-00019 drawing for more information.

6.0 MAINTENANCE

Series 98 actuators are designed for long service periods between maintenance, in demanding conditions. However, a preventative maintenance program is essential for ensuring good performance, safe operation, extended life of equipment and to avoid expensive down time.

The service conditions, load and cycling frequency may vary largely, which would require the maintenance program to be suitably designed, with sound judgment of the working conditions. Contact manufacturer for assistance.

In general, the scheduled service shall include replacement of all seals and wear parts.

Seals shall be replaced if the actuator is in storage or inactive for long periods of time.

6.1 Lubricants and Maintenance Consumables

The Standard actuators use following lubricants, contact factory for information on high/low temperature actuator lubricants,

Shell Alvania EP2 (LF) grease for the Torque & Spring Modules

Molykote 55 for the Pressure Module.

ISO Grade 32 hydraulic fluid for hydraulic override

Thread lock compound: Loctite 243 (or equivalent)

Thread Sealant: Loctite 577(or equivalent)

Commercial leak check fluid: Snoop (or equivalent)

Anti seize compound: Loctite 77164 (or equivalent)

6.2 Disassembly, Service & Reassembly of Modules

CAUTION

Prior to disassembly of the actuator, disconnect all air and electrical supplies from actuator, remove the relevant accessories from actuator and dismount actuator from valve (or override gearbox, if present).

NOTICE

Replacement of the press fitted bushings may require workshop infrastructure to remove the worn bearings from their housing and to press fit new ones, without damaging the housings. We recommend sending the actuator (or module) to our factory for overhauls/major repairs.

References:

Drawing # ES-00019 – Spring Return Actuator Assembly

Drawing # ES-00020 – DA Assembly

Drawing # ES-00021 – DD Assembly

(Refer to the Bray website for current revisions of the drawings)

6.3 Spring Module

WARNING

Follow the sequence of steps as described below. Injury or damages may occur if critical steps are bypassed or shortcuts taken.

Never attempt to cut open the Spring Module welded assembly as the spring inside is energized and can cause fatal/severe injury or extensive damages.

Note: If the actuator is provided with a jackscrew or hydraulic override cylinder on the Spring Module, first ensure to back off the override fully, to unload it from any spring force. Remove the override assembly before disassembling Spring Module.

6.3.1 Removing the Spring Module

(Refer to the Spring Return Pneumatic Actuator Assembly drawing)

1. Slacken the Spring Module side Travel Stop Bolt Lock Nuts (18) on the torque module (and extended stopper, if provided). Apply air pressure to pressure module adaptor port (rod end port), raising pressure slowly, enough to release spring force on the Travel Stop Bolt (19).
2. Mark the set position and back off fully both the Stop Bolts (and Extended Stopper/Jackscrew, if present) and release air pressure. This will relieve the spring preload.

CAUTION

Never try to loosen the Spring Rod without completely relieving the spring load on it.

3. Remove the Extended Stopper/ override assembly, if present, from the Spring Module by unfastening the bolts holding the assembly on the End Cap (49).



WARNING

The Spring Module is welded into an integral component and the internal components cannot be disassembled.

Spring within is under compression. Never attempt to modify or cut open this module.

Do not dispose of the spring module in metal scrap unless it is appropriately disarmed.

4. To take the Spring Module off the actuator, unscrew the End Cover Bolts (58), remove the End Cover (55) and the O-ring (59). Using an extended socket spanner /tube spanner, unscrew and disconnect the Spring Rod (54) from the Guide Block (25) in Torque Module. A retainer ring on the threaded side of the Spring Rod stops it from being taken out of the Spring Module.
5. Sling and support the Spring Module and remove the Module's mounting flange Stud Nuts (61) and Lock washers (62). Spring Module can now be pulled off the Torque Module. Pull off the module carefully so as not to damage the threads on the Spring Rod and studs on the Adaptor.

6.3.2 Service & Reassembly of the Spring Module

Ensure that a correct Repair Kit is on hand, prior to disassembly.

1. Take the Retainer Ring (56) off and pull the Spring Rod out from the cover end.
2. Replace the Bushing (Adaptor) (36), clean and lubricate the Spring Rod and slide it back in.
3. Install the Retainer Ring back in the Spring Rod groove.
4. Fit the Module back on Torque Module with new O-ring (63).
5. Fit End Cover back with new O-ring (59).

6.4 Pressure Module



CAUTION

Ensure the ports are vented to atmosphere before disassembly of Pressure Module. Failure to do so could cause severe injury.

To take the Pressure Module off the Spring Return Actuator, first the Spring Module must be removed or at least the Spring Rod must be disconnected from the Guide Block (steps 1-4), as described in section 6.3.1.

6.4.1 Removing the Pressure Module from Actuator

1. For Spring return actuators the spring rod shall be first disconnected following the steps 1-4 of 6.3.1. For Double acting actuators skip this step.
2. Apply low pressure air (5 to 7 psi) to the adaptor port (rod end side port) to move the piston to end cap side.
3. Depressurize and remove the Plug (46) (or cover plate) on the End Cap (34).
4. Use an extended socket or tube spanner and unscrew the Piston Rod (35) from the Guide Block (25) in Torque Module.
5. Sling and support the Pressure Module. Remove the Adaptor Stud Nuts (61) and Lock washers (62). Pressure Module can now be pulled off the Torque Module. Pull off the module carefully so as not to damage the threads on the Piston Rod and studs on the Adaptor.
6. Ensure the Module sealing O-ring (63) is retained in the groove.

6.4.2 Disassembling the Pressure Module

1. Secure the Module and unscrew the Tie Rod Nuts (40).
2. Gently tap the End Cap (34) off the cylinder Barrel (32) with a plastic mallet and remove the End Cap.
3. Slide the Barrel over and off the Adaptor (31) and Piston (33), being careful not to scratch or dent the honed and chrome plated surface of the barrel.
4. Take the Piston Assembly off the Adaptor, taking care not to damage the threads.
5. Tie Rods (39) may be unscrewed from the Adaptor Plate.
6. Remove the Retainer Ring (45) and take the Split Collars (38) off the Piston Rod (35) upper groove. Pull the Piston Rod off the Piston and remove the Split Collars from the lower groove.

6.4.3 Service & Reassembly of the Pressure Module

NOTICE

The wear parts (all seals, piston wear bands and rod guide bushings in the Repair Kit) shall be replaced during the maintenance cycle. Ensure the replacement seals are suitable for the service temperature. Remove old seals and clean all the parts thoroughly.

The assembly of the Pressure Module is done in vertical orientation.

Use Dow Corning Molykote 55 lubricant in the Pressure Module.

1. To reassemble, secure the Adaptor Plate horizontally, after replacing the Bushing (36), with sufficient space below, to accommodate the Piston Rod. The rod seal groove side of the Adaptor faces upwards.

2. Lubricate the piston rod U-cup Seal (37) and insert it in the groove in Adaptor Plate with the seal lip towards piston side.
3. Lubricate and install the Adaptor O-ring (44).
4. Lubricate the piston rod O-ring (41) and install in the groove on the piston rod.
5. Grease and slip in the Split Collars on the Piston Rod lower groove and slide in the Piston Rod (hex side) through the Piston till the split collars locate in the counter bore in the piston.
6. Install the Split Collars on the upper groove similarly and secure it by the Spiral Retainer Ring.
7. Lubricate the Piston Rod and carefully slide in the Piston Assembly through the Rod Seal and Bushing in the Adaptor. Beware of the pinch points between the Piston and the Adaptor while lowering the Piston Assembly on the Adaptor inner face.
8. Lubricate and install the Wear Bands (42) and the Piston Quad Seal (43) on the Piston.

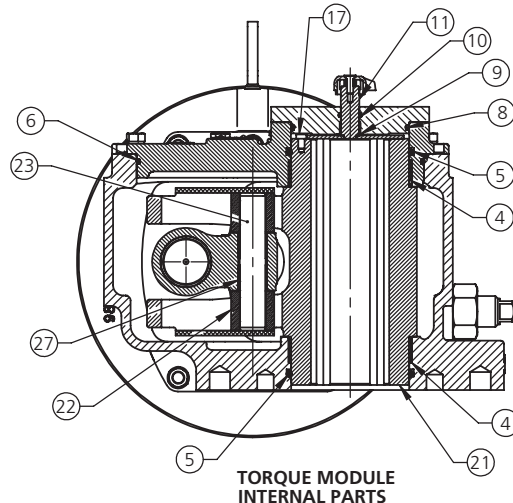
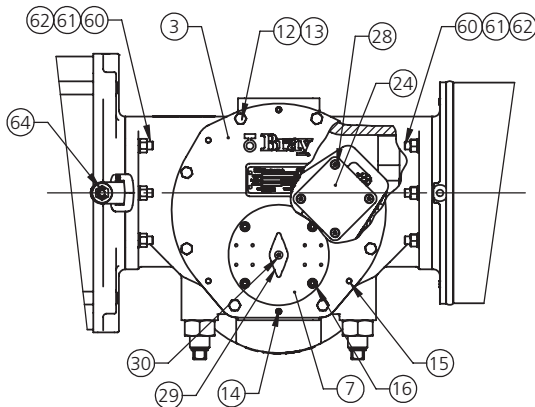
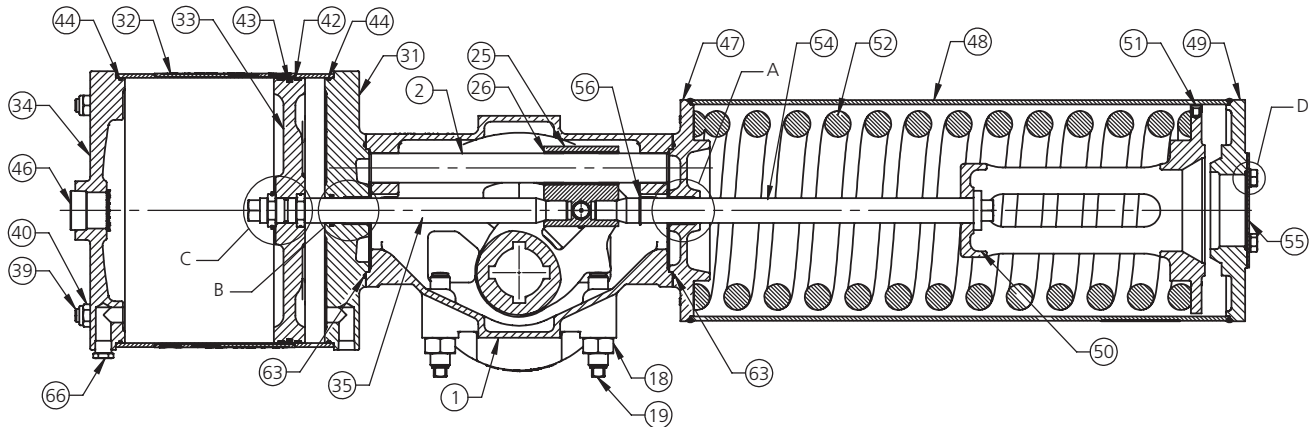

9. Carefully lift and slide in the Barrel over the Piston Wear Bands, Quad Seal and Adaptor O-ring and push it down on to the Adaptor.
10. Thread the Tie Rods into the Adaptor, use thread lock compound on the threads.
11. Lubricate the inside of the Barrel and slide in the End Cap, aligning the ports on the Adaptor and the End Cap.
12. Fasten the assembly with Tie Rod Nuts tightened to the recommended torque. (Refer to Section 10 Bolting Torque Tables)
13. Lift the Module using lifting eye bolts threaded into the End Cap and place it horizontally. Put back the Plug/End Cover on the End Cap to test the module.
14. Apply 10-15 psi air pressure to ports alternately to check for smooth stroking for 5-10 cycles and then raise to 80 psi and hold the pressure to check for any leaks past the Piston, through the Rod Seal and the Barrel O-rings.

Leak test the piston seal by bubble test at 80 psi pressure and for other seals check visually using commercial leak check fluids (Snoop or equivalent).

Leakage rate after hold down time shall not be much higher than 1-2 bubbles per minute with a 1/4" ID tube.

Stroke the piston a few times to set the seals if leakage is higher, and repeat the bubble test. If still not within the limits, dismantle the module to examine the cause.

15. If no abnormalities are seen, the Module is ready for assembly on the Torque Module.

6.5 Torque Module

6.5.1 Disassembling the Torque Module

NOTICE

For SR actuators, the Spring Module or the Pressure Module must be removed from the Torque Module to allow for removal of the Guide Bar and Yoke Assembly from the Torque Module.

For DA actuators, remove the end cover on the Torque Module.

1. Disconnect the Piston Rod (35) and the Spring Rod (54) from the Guide Block prior to disassembly.
2. Remove the position Indicator (29), if provided.
3. Remove Top Cover Bolts (16) and the Top Cover (7).
4. Take off the Accessory Drive Shaft Assembly (11) from top of the Yoke.

5. Remove the Housing Cover Bolts (12) and Lock Washers (13).
6. Tighten the two Set Screws (14) on the Housing Cover (3), half turn at a time alternately till the Housing Cover is separated enough to pry off the Housing with a blunt tool.
7. Gently tap with plastic hammer or pull off the Guide Bar (2) from the Guide Block (25) and the Housing (1).
8. Rotate and center the Yoke Assembly, move the Guide Block towards the Yoke center and lift the Yoke Assembly out of Housing.

NOTICE

For smaller models (up to 14E3) this can be done by hand. Larger models may require use of a hoist to support the weight of the Yoke sub-assembly. For this, remove the Screw (17) off the Yoke and fit an eye bolt in place.

9. Secure the Yoke Assembly and remove the Retainer Plate Screws (28) and the Retainer Plate (24).
10. Pull out the Yoke Pin (23), and the upper Slider Block (22).
11. Slide the Guide Block out of the Yoke (21) and remove the bottom Slider Block.
12. Remove the Yoke sealing O-rings (5) from the Housing and Housing Cover, if replacement is required.
13. The Yoke Bushing (4) in the Housing and the Housing Cover, the Guide Bar Bushing (26) and Yoke Pin Bushing (27) in the Guide Block are press fitted and may need suitable workshop tools for removal without damaging the housing.

6.5.2 Service & Reassembly of the Torque Module

Note: Thoroughly clean/degrease all components prior to assembly.

1. Replace the bushings in the Housing, the Housing Cover and the Guide Block with suitable pressing tools. Contact factory for more information.
2. Secure the Yoke and fit the bottom Retainer Plate (24) with Screws (28), applying a drop of thread lock compound on the screw threads.
3. Flip the Yoke over, grease the bottom slot and the Slider Block (22) generously and slide the Slider Block into the slot.

- Grease the Guide Block bushings and slide the Guide Block between the arms of the Yoke aligning the Yoke Pin bushings with the lower Slider Block pin hole.
- Grease the Yoke Pin (23) and slide it through the upper slot in the Yoke and the Guide Block pin bearings, locating it in the lower Slider Block hole. Push the Yoke Pin down to touch the bottom Retainer Plate.
- Grease the upper slot and the Slider Block and slide it down on the Yoke Pin through the upper slot till it rests on the Guide Block.
- Fit the upper Retainer Plate to complete the Yoke Assembly.
- Lubricate and Install the Yoke O-ring (5) in the Housing and grease the bushing and the Yoke seating raised face.
- Carefully slide in the Yoke Assembly into the Housing bushing and push it down to seat it on the raised seating face in the Housing.
- Grease and slide in the Guide Bar (2) through the Housing and Guide Block.
- If removed previously, screw back the accessory drive shaft assembly Screw (17) on top of the Yoke, applying a drop of thread lock compound. Grease the upper journal of the Yoke.
- Lubricate and install the Yoke O-ring and Cover O-ring (6) in the Housing Cover. Ensure the two set screws on the Housing Cover are fully backed off. Locate the Housing Cover on the Yoke's upper journal and fit it on the Housing with the Cover Bolts (12).
- Locate the Accessory Drive Shaft Assembly on the top of the Yoke, locating the plate slot into the screw head.
- Replace the flanged bushing and the O-rings in the Top cover and fit it back on the Housing Cover with the Top Cover Bolts. Fit the indicator on the drive shaft.
- Apply anti-seize compound on the stopper bolt threads and thread them with the Lock Nuts into the Torque Module Housing.
- Carefully guide the Studs into the flange and center the module on the spigot (centering ring).
- Fasten the modules with Spring Washers and Stud Nuts, refer to the tables for torque values.
- Take the Plug/End Cover off the End Cap of the Pressure Module and couple the Piston Rod threads to the Guide block, using an extended socket or tube spanner. Refer to the tables in Section 10 for torque values.
- Install the Plug (or End Cover) with thread sealant and apply low pressure air (5psi) on the End Cap port till the Yoke reaches end of stroke. Restrain the Guide Bar from sliding out of the Housing while stroking.
- For DA models (refer to Drawing #ES-00020-DA Assembly), fit the DA End Cover (52) with O-ring (47) in the groove, using Bolts (51), Nuts (50) and Spring Washers (49). Skip to step 12.
- For DD models, mount the second Pressure Module on the other side of Torque Module, following relevant actions from steps 3 through 7. Skip to step 12.
- For Spring Return Models, mount the Spring Module on the other side of the Torque Module in same manner as the Pressure Module and couple the Spring Rod to Guide Block just as was done with the Piston Rod. Always ensure to tighten the Piston and the Spring Rod to the recommended torque.
- Fix the End Cover with O-ring on the Spring Module (or the Extended Travel Stop/Jackscrew Assembly/Hydraulic override cylinder, if provided).
- Set the Travel Stops to previously marked positions. For spring return actuator, connect air pressure line to the adaptor port (rod end side port) and slowly raise pressure enough to start the yoke rotation, to be able to adjust the spring module side travel stop bolt.
- Test the actuator for smooth operation at the Maximum Operating Pressure, as noted on the nameplate.

6.6 Reassembly of Actuator

- Secure the Torque Module on its base.
- Back off the travel Stop Bolts (19) fully and manually turn the Yoke to the side on which the Pressure Module is to be fixed.
- Lift the Pressure Module, lubricate and place the module flange O-ring in the groove. Degrease the Piston Rod threads, apply a drop of thread lock compound on the threads and locate the module on the Torque Module's mounting flange.

7.0 FIELD CONVERSIONS

7.1 Fail Safe Condition (for Spring Return Actuators)

Prior to configuration change, refer to the torque charts and ensure the actuator's torques would be suitable for the new application.

The fail safe direction on Series 98 spring return actuator can be reversed from fail CW to fail CCW and vice versa. This requires interchanging the position of Pressure and Spring Modules.

NOTICE





It is strongly recommended to take the actuator off the valve to do the fail safe reversal.

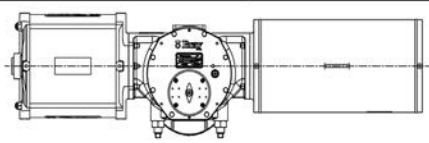

CAUTION

Never try to unscrew and remove the Spring Rod without completely relieving the spring load on it.

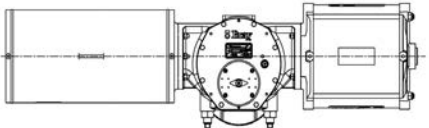
1. Follow the steps for removing the Spring and Pressure Modules from the actuator, as described in Sections 6.3 and 6.4 respectively.
2. Switch the positions of the two modules, mount the Pressure Module first. Take care to seat the module sealing O-ring properly in the groove. Pressure Module will need to be flipped about its' axis before mounting if the supply ports are required to be on the front side of the actuator.
3. Follow instructions in Section 6.6 Reassembly of the Actuator.
4. Follow Sec. 3.0 to mount the Actuator back on the valve/gearbox and adjust the travel stop bolts, as required for proper valve operation. Tighten the Lock Nuts on the travel Stop Bolts.
5. Check actuator for proper operation, at the rated working pressure.

Actuator Configuration	Fail Direction
	CW 
	CCW 

NOTICE

Actuator part number and fail direction needs to be suitably changed on the name plate, after completing any configuration change. Refer to Technical Manual or contact factory for information.

7.2 Double Acting to Spring Return

1. To convert the DA actuator to Spring Return (SC or SO), a Spring Module will need to be mounted opposite the Pressure Module with a Module Mounting Kit.
2. If the Pressure Module needs to be shifted, for the required configuration of the Spring Return actuator, then first remove the Pressure Module from the actuator. Follow the procedure in Section 6.4 to remove the Pressure Module and Section 6.6 for Reassembly of Actuator. Skip this step if shifting the Pressure Module is not required.
3. Remove the DA End Cover (52), (refer to Drawing #ES-00020 – DA Assembly).
4. Tighten the Studs from Module Mounting Kit into the Spring Module Adaptor, applying thread lock compound on the threads. Install the module O-ring in adaptor groove.
5. Follow steps in Section 6.6 for Reassembly of the Actuator.
6. Set the travel Stop Bolts on the Torque Module as required for proper valve seating.
7. Remove the air connection from the End Cap port of the Pressure Module and replace the connector with a breather-filter.
8. The Spring Return Actuator requires air connection only on the Adaptor port.

7.3 Spring Return to Double Acting

1. Remove Spring Module from actuator (refer to Section 6.3).
2. Fit DA End Cover with O-ring and fasteners from the DA Cover Kit.
3. Adjust travel Stop Bolts, as required.
4. Remove the breather-filter from the End Cap of the Pressure Module and connect suitable connector for connecting the air line from the direction control valve.

8.0 Pneumatic Actuator - Double Acting, Single Cylinder Assembly and Materials of Construction

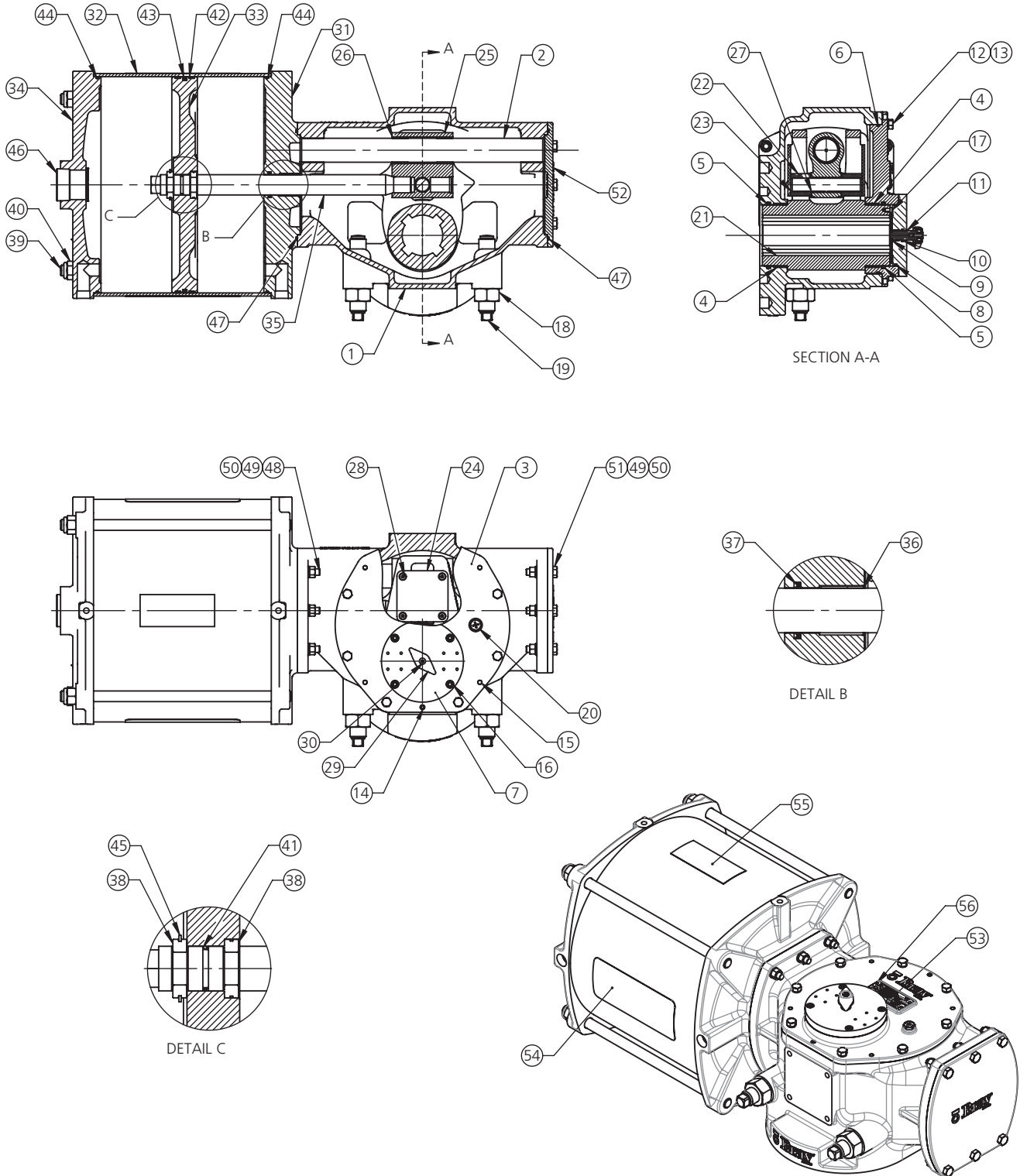

For reference only. Please refer to current revision of ES-00020 drawing for more information.

ITEM		DESCRIPTION	MATERIAL	QTY.
1		Yoke Housing	Ductile Iron	1
2		Guide Rod	Alloy Steel	1
3		Housing Cover	Ductile Iron	1
4	**	Bushing (Yoke)	PTFE Bronze	2
5	*	O-ring (Yoke)	Buna-n	2
6	*	O-ring (Cover)	Buna-n	1
7		Top Cover	Ductile Iron	1
8	*	O-ring (Top Cover)	Buna-n	1
9	**	Flanged Bushing	PTFE Bronze	1
10	*	O-ring (Accessory Drive)	Buna-n	1
11		Accessory Drive	Stainless Steel	1
12		Hex Bolt	Steel	8
13		Spring Washer	Spring Steel	8
14		Set Screw, Socket Head	Steel	2
15		Dowel Pin	Hardened Steel	4
16		Socket Head Caps Screw,	Steel	4
17		Socket Head Caps Screw, Low Head	Steel	1
18		Seal Nut	Steel	2
19		Stop Bolt	Steel	2
20		Breather Vents	Carbon Steel	1
21		Yoke	Ductile Iron	1
22	**	Slider Block	Bronze	2
23		Yoke Pin	Alloy Steel	1
24		Retainer Plate	Plastic	2
25		Guide Block	Carbon Steel	1
26	**	Bushing (Guide Rod)	PTFE Bronze	2
27	**	Bushing (Yoke Pin)	PTFE Bronze	2
28		Cap Screw, Flat Head, Hex Socket	Steel	8

ITEM		DESCRIPTION	MATERIAL	QTY.
29		Position Indicator	Plastic	1
30		Cap Screw, Flat Head, Hex Socket	Steel	1
31		Adaptor, Pressure Module	Ductile Iron	1
32		Barrel	Carbon Steel	1
33		Piston	Ductile Iron	1
34		End Cap, Pressure Module	Ductile Iron	1
35		Piston Rod	Alloy Steel	1
36	**	Bushing (Adaptor)	PTFE Bronze	1
37	*	Seal, U-cup	Buna-n	1
38		Split Collar	Alloy Steel	4
39		Tie Rod	Steel	4
40		Locknut, Nylok	Steel	4
41	*	O-ring (Piston Rod)	Buna-n	1
42	*	Wear Ring	PTFE	2
43	*	Quad Seal	Buna-n	1
44	*	O-ring (Barrel)	Buna-n	2
45		Retainer Ring	Stainless Steel	1
46		Pipe Plug	Carbon Steel	1
47	*	O-ring (Module)	Buna-n	2
48		Stud	Steel	6
49		Spring Washer	Spring Steel	12
50		Nut	Steel	12
51		Hex Bolt	Steel	6
52		End Cover, Da	Ductile Iron	1
53		Name Plate	Stainless Steel	1
54		Label, Logo	Metallized Polyester	2
55		Label, Configuration	Metallized Polyester	1
56		Rivets	Stainless Steel	4

*	Parts in Seal Kits
* & **	Parts in Repair Kits

For reference only. Please refer to current revision of ES-00020 drawing for more information.

9.0 Pneumatic Actuator - Double Acting, Dual Cylinder Assembly and Materials of Construction

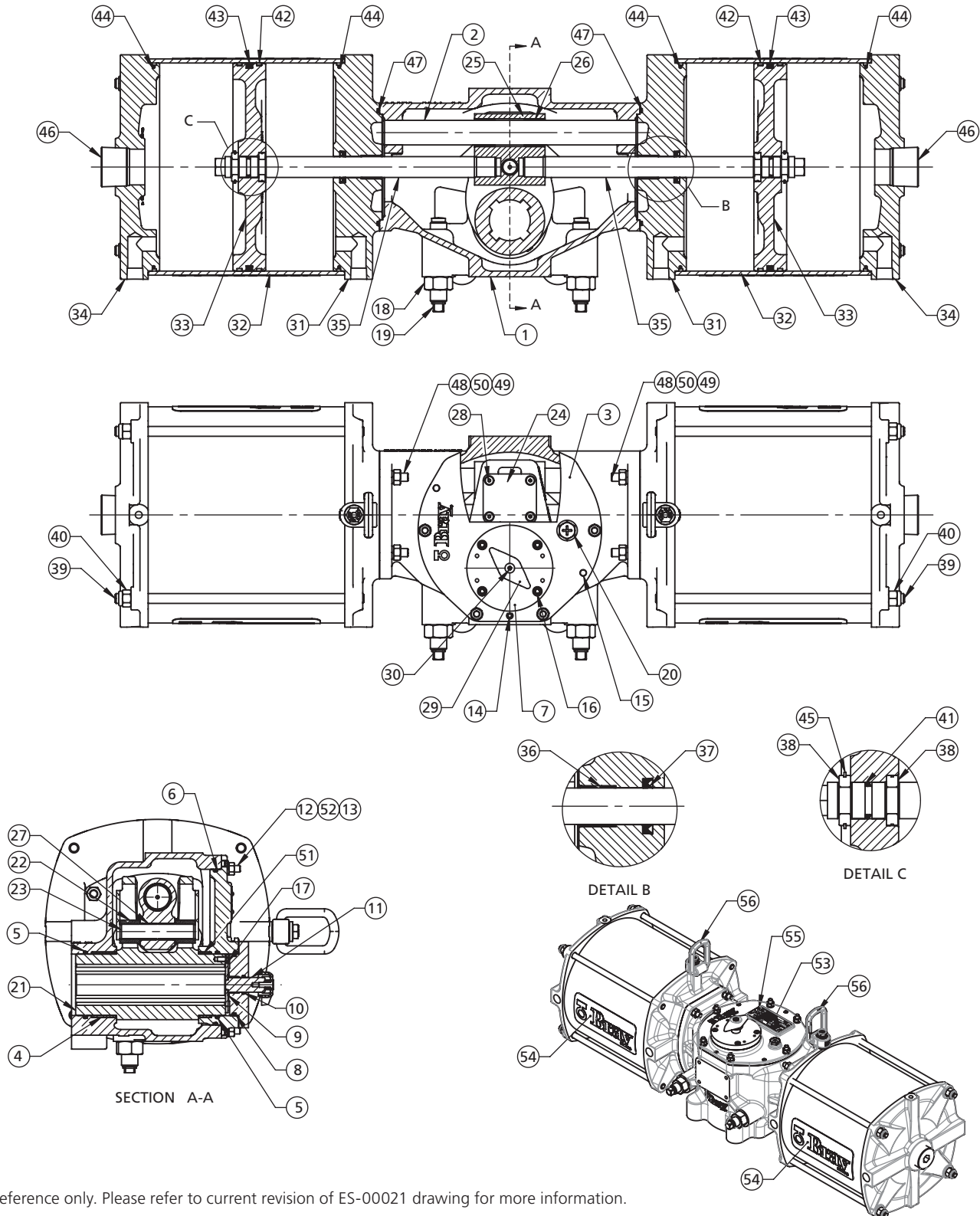

For reference only. Please refer to current revision of ES-00021 drawing for more information.

ITEM		DESCRIPTION	MATERIAL	QTY.
1		Yoke Housing	Ductile Iron	1
2		Guide Rod	Alloy Steel	1
3		Housing Cover	Ductile Iron	1
4	**	Bushing (Yoke)	PTFE Bronze	2
5	*	O-Ring (Yoke)	Buna-N	2
6	*	O-Ring (Cover)	Buna-N	1
7		Top Cover	Ductile Iron	1
8	*	O-Ring (Top Cover)	Buna-N	1
9	**	Flanged Bushing	PTFE Bronze	1
10	*	O-Ring (Accessory Drive)	Buna-N	1
11		Accessory Drive	Stainless Steel	1
12		Hex Bolt	Steel	8
13		Spring Washer	Spring Steel	8
14		Set Screw, Socket Head	Steel	2
15		Dowel Pin	Hardened Steel	4
16		Socket Head Caps Screw	Steel	4
17		Socket Head Caps Screw, Low Head	Steel	1
18		Seal Nut	Steel	2
19		Stop Bolt	Steel	2
20		Breather Vents	Carbon Steel	1
21		Yoke	Ductile Iron	1
22	**	Slider Block	Bronze	2
23		Yoke Pin	Alloy Steel	1
24		Retainer Plate	Plastic	2
25		Guide Block	Carbon Steel	1
26	**	Bushing (Guide Rod)	PTFE Bronze	2
27	**	Bushing (Yoke Pin)	PTFE Bronze	2
28		Cap Screw, Flat Head, Hex Socket	Steel	8

ITEM		DESCRIPTION	MATERIAL	QTY.
29		Position Indicator	Plastic	1
30		Cap Screw, Flat Head, Hex Socket	Steel	1
31		Adaptor, Pressure Module	Ductile Iron	2
32		Barrel	Carbon Steel	2
33		Piston	Ductile Iron	2
34		End Cap, Pressure Module	Ductile Iron	2
35		Piston Rod	Alloy Steel	2
36	**	Bushing (Adaptor)	PTFE Bronze	2
37	*	Seal, U-Cup	Buna-N	2
38		Split Collar	Alloy Steel	8
39		Tie Rod	Steel	8
40		Locknut, Nylok	Steel	8
41	*	O-Ring (Piston Rod)	Buna-N	2
42	*	Wear Ring	PTFE	4
43	*	Quad Seal	Buna-N	2
44	*	O-Ring (Barrel)	Buna-N	4
45		Retainer Ring	Stainless Steel	2
46		Pipe Plug	Carbon Steel	2
47	*	O-Ring (Module)	Buna-N	2
48		Stud	Steel	12
49		Spring Washer	Spring Steel	12
50		Nut	Steel	12
51	**	Bushing (Yoke)	PTFE Bronze	1
52		Nut	Steel	6
53		Name Plate	Stainless Steel	1
54		Label, Logo	Metallized Polyester	4
55		Rivets	Stainless Steel	4
56		Lifting Eye Bolt	Carbon Steel	2

*	Parts in Seal Kits
* & **	Parts in Repair Kits

For reference only. Please refer to current revision of ES-00021 drawing for more information.

10.0 BOLTING TORQUES AND TOOLS

10.1.a - Pressure Module

	5	6	7	8	9	10	12	14	16	18	20	22	24	28	32	36
Tie Rod Thread	M8	M8	M10	M10	M12	M12	M16	M16	M20	M20	M24	M24	M30	M24	M30	M30
Spanner Size, mm	13	13	17	17	19	19	24	24	30	30	36	36	46	36	46	46
Torque, Nm	10	15	20	25	35	45	80	110	180	230	335	410	610	330	540	685
End Plug, NPT	1.25"	1.25"	1.25"	1.25"	1.5"	1.5"	2"	2"	2"							
Allen Key, inch	.75"	.75"	.75"	.75"	1"	1"	1"	1"	1"							
End Cover Bolts										M10	M10	M10	M10	M10	M10	M10
Spanner Size, mm										17	17	17	17	17	17	17
Torque, Nm										25	25	25	25	25	25	25

Consumables

Thread Sealant	Loctite 577 / Equivalent
Thread Lock	Loctite 243 / Equivalent
Lubricant	Dow Corning Molykote 55 (for Standard Actuators). Contact Factory for Low/High temp trim lubricants.

10.1.b - Pressure Module

MODEL	12 E2	18 E2	45 E2	73 E2	14 E3	24 E3	45 E3	10 E4
Piston Rod Diameter, inch	0.875	1	1	1.25	1.5	1.75	2.25	2.75
Rod Thread	M20x2	M24x2	M24x2	M27x2	M30x2	M36x3	M48x3	M60x4
Piston Rod Hex A/F, mm	18	21	21	26	32	36	46	55
Torque, Nm	150	200	200	200	250	250	350	450
Piston Rod Minimum No of Turns	10	12	10	14	15	12	16	15

10.2 - Torque Module

MODEL	12 E2	18 E2	45 E2	73 E2	14 E3	24 E3	45 E3	10 E4
Housing Cover Bolts/ Studs	M8	M8	M8	M8	M10	M12	M12	M16
Spanner Size, mm	13	13	13	13	17	19	19	24
Torque, Nm	13	13	13	13	25	50	50	115
Retainer plate Screws	M5	M5	M5	M6	M6	M6	M6	M8
Allen Key, mm	3	3	3	4	4	4	4	5
Acc Drive Screw			M6	M6	M6	M8	M8	M10
Allen Key, mm			5	5	5	6	6	8
Top Cover Bolts	M6	M6	M6	M8	M8	M8	M8	M10
Allen Key, mm	5	5	5	6	6			
Spanner Size, Metric						13	13	17

Consumables

Thread Sealant	Loctite 577 / Equivalent
Thread Lock	Loctite 243 / Equivalent
Anti seize	Loctite Ni Anti Seize
Lubricant	Shell Alvania Lead free EP2 Grease (for Standard Actuator). Contact factory for Low/High temperature trim lubricants.

10.3 - Spring Module

MODEL	12 E2	18 E2	45 E2	73 E2	14 E3	24 E3	45 E3	10 E4
Spring Rod Diameter, inch	0.875	1	1	1.25	1.5	1.75	2.25	2.75
Rod Thread	M20x2	M24x2	M24x2	M27x2	M30x2	M36x3	M48x3	M60x4
Spring Rod Hex A/F, mm	18	21	21	26	32	36	46	55
Torque, Nm	150	200	200	200	250	250	350	450
Spring Rod Minimum No. of Turns	10	12	10	14	15	12	16	15
End Cover Bolt	M10	M10	M12	M12	M16	M16	M16	M20
Spanner Size, mm	17	17	19	19	24	24	24	30

10.4 - Actuator Assembly

MODEL	12 E2	18 E2	45 E2	73 E2	14 E3	24 E3	45 E3	10 E4
ISO Base	F12/ F07	F12	F16/ F12	F16/ F12	F25/ F16	F30/ F25	F35/F30	F40/F35
Base Bolting Size	M12/M8	M12	M20/M12	M20/M12	M16/M20	M20/M16	M30/M20	M36/M30
Module Mounting Stud- Nut Size	M8	M10	M10	M12	M12	M16	M16	M24
Spanner Size , Metric	13	17	17	19	19	24	24	36
Torque, Nm	20	40	40	70	70	165	165	545

Consumables

Thread Sealant	Loctite 577 / Equivalent
Thread Lock	Loctite 243 / Equivalent
Lubricant	Shell Alvania Lead free EP2 Grease (for Standard Actuator). Contact factory for Low/High temperature trim lubricants.

11.0 TECHNICAL DATA

11.1 - Double Acting Actuators

Model	Maximum Operating Pressure					Volume				Actuator Weight		Assembly Weight (approx)			
	Symmetrical		Canted			Cu.in		Lts		Lbs	Kg	w/Jackscrew Override		w/Hydraulic Override	
	psi	bar	psi	bar	psi	bar	Rod End	Cap End	Rod End			Cap End	Lbs	Kg	Lbs
DA	12E2-05	150	10.3	150	10.3	84	94	1.4	1.5	60	27	86	40		
	12E2-06	140	9.7	116	8.0	124	137	2.0	2.2	62	28	88	41		
	12E2-07	103	7.1	85	5.9	170	187	2.8	3.1	68	31	95	44		
	12E2-08	79	5.4	65	4.5	223	244	3.7	4.0	82	37	108	50		
	12E2-09	62	4.3	51	3.5	285	309	4.7	5.1	90	41	117	54		
DD	12E2-05	103	7.1	85	5.8	178	178	2.9	2.9	86	39				
	12E2-06	71	4.9	58	4.0	261	261	4.3	4.3	90	41				
	12E2-07	52	3.6	43	2.9	358	358	5.9	5.9	104	47				
	12E2-08	40	2.7			468	468	7.7	7.7	130	59				
DA	18E2-06	150	10.3	139	9.6	146	163	2.4	2.7	90	41	134	61		
	18E2-07	124	8.5	102	7.0	200	223	3.3	3.6	95	43	139	63		
	18E2-08	95	6.5	78	5.4	266	289	4.4	4.7	112	51	157	71		
	18E2-09	75	5.2	62	4.2	344	366	5.6	6.0	121	55	165	75		
	18E2-10	61	4.2	50	3.4	429	467	7.0	7.7	141	64	185	84		
DD	18E2-06	85	5.9	70	4.8	310	310	5.1	5.1	126	57				
	18E2-07	62	4.3	51	3.5	423	423	6.9	6.9	134	61				
	18E2-08	48	3.3			555	555	9.1	9.1	170	77				
DA	45E2-08	150	10.3	150	10.3	322	346	5.3	5.7	143	65	207	94		
	45E2-09	144	9.9	119	8.2	417	442	6.8	7.2	152	69	216	98		
	45E2-10	117	8.0	96	6.6	519	560	8.5	9.2	172	78	236	107		
	45E2-12	81	5.6	67	4.6	750	831	12.3	13.6	209	95	273	124		
	45E2-14	59	4.1	49	3.4	1020	1135	16.7	18.6	267	121	331	150		
DD	45E2-08	92	6.3	76	5.2	669	669	11.0	11.0	203	92				
	45E2-09	72	5.0	60	4.1	858	858	14.1	14.1	220	100				
	45E2-10	59	4.0	48	3.3	1079	1079	17.7	17.7	260	118				
	45E2-12	41	2.8			1581	1581	25.9	25.9	335	152				
DA	73E2-10	150	10.3	127	8.7	621	668	10.2	11.0	245	111	331	150	359	163
	73E2-12	107	7.4	88	6.1	902	985	14.8	16.2	280	127	366	166	395	179
	73E2-14	78	5.4	65	4.4	1227	1347	20.1	22.1	331	150	417	189	445	202
	73E2-16	60	4.1	49	3.4	1588	1766	26.0	29.0	399	181	485	220	514	233
	73E2-10	77	5.3	64	4.4	1289	1289	21.1	21.1	344	156				
DD	73E2-12	54	3.7	44	3.0	1887	1887	30.9	30.9	414	188				
DA	14E3-12	150	10.3	142	9.8	1071	1152	17.6	18.9	386	175	534	242	558	253
	14E3-14	127	8.7	104	7.2	1458	1574	23.9	25.8	437	198	584	265	608	276
	14E3-16	97	6.7	80	5.5	1890	2061	31.0	33.8	507	230	655	297	679	308
	14E3-18	77	5.3	63	4.3	2421	2626	39.7	43.1	591	268	739	335	763	346
	14E3-20	62	4.3	51	3.5	2978	3300	48.8	54.1	721	327	869	394	893	405
DD	14E3-12	87	6.0	72	4.9	2223	2223	36.5	36.5	536	243				
	14E3-14	64	4.4	52	3.6	3032	3032	49.7	49.7	637	289				
	14E3-16	49	3.4	40	2.8	3951	3951	64.8	64.8	778	353				
DA	24E3-14	150	10.3	134	9.2	1831	1954	30.0	32.0	657	298	873	396	910	413
	24E3-16	124	8.6	102	7.1	2387	2560	39.2	42.0	721	327	937	425	974	442
	24E3-18	98	6.8	81	5.6	3059	3255	50.2	53.4	800	363	1016	461	1054	478
	24E3-20	80	5.5	66	4.5	3750	4084	61.5	67.0	941	427	1157	525	1195	542
	24E3-22	66	4.5	54	3.7	4561	5012	74.8	82.2	1041	472	1257	570	1294	587
	24E3-24	55	3.8	46	3.1	5452	5917	89.4	97.0	1208	548	1424	646	1462	663
DD	24E3-14	82	5.6	67	4.6	3785	3785	62.1	62.1	886	402				
	24E3-16	63	4.3	52	3.5	4948	4948	81.1	81.1	1014	460				
	24E3-18	49	3.4			6314	6314	103.5	103.5	1173	532				
	24E3-20	40	2.8			7834	7834	128.5	128.5	1455	660				

11.1 - Double Acting Actuators - Continued

	Model	Maximum Operating Pressure				Volume				Actuator Weight		Assembly Weight (approx)			
		Symmetrical		Canted		Cu.in		Lts		Lbs	Kg	w/Jackscrew Override		w/Hydraulic Override	
		psi	bar	psi	bar	Rod End	Cap End	Rod End	Cap End			Lbs	Kg	Lbs	Kg
DA	45E3-18	150	10.3	123	8.5	3722	3895	61.0	63.9	1105	501			1457	661
	45E3-20	121	8.4	100	6.9	4584	4878	75.2	80.0	1241	563			1594	723
	45E3-22	100	6.9	83	5.7	5591	5973	91.7	98.0	1345	610			1698	770
	45E3-24	84	5.8	69	4.8	6676	7068	109.5	115.9	1515	687			1867	847
	45E3-28	62	4.3	51	3.5	9074	9699	148.8	159.1	1942	881			2295	1041
DD	45E3-18	75	5.2	62	4.3	7617	7617	124.9	124.9	1543	700				
	45E3-20	61	4.2	50	3.5	9462	9462	155.2	155.2	1817	824				
	45E3-22	50	3.5	41	2.9	11564	11564	189.7	189.7	2024	918				
	45E3-24	42	2.9			13745	13745	225.4	225.4	2363	1072				
DA	10E4-22	150	10.3	150	10.3	6875	7205	112.8	118.2	2092	949			2698	1224
	10E4-24	150	10.3	126	8.7	8173	8504	134.0	139.5	2269	1029			2875	1304
	10E4-28	113	7.8	93	6.4	11049	11713	181.2	192.1	2754	1249			3360	1524
	10E4-32	86	5.9	71	4.9	14589	15908	239.3	260.9	3309	1501			3915	1776
	10E4-36	68	4.7	56	3.9	18327	19859	300.6	325.7	4017	1822			4623	2097
DD	10E4-22	92	6.3	76	5.2	14080	14080	230.9	230.9	2873	1303				
	10E4-24	77	5.3	64	4.4	16676	16676	273.5	273.5	3225	1463				
	10E4-28	57	3.9	47	3.2	22763	22763	373.3	373.3	4195	1903				
	10E4-32	43	3.0			30497	30497	500.2	500.2	5306	2407				

11.2 - Spring Return Actuators

Model	Spring #	Maximum Operating Pressure				Volume		Actuator Weight		Assembly Weight (approx)			
		Symmetrical		Canted		Rod End		Lbs	Kg	w/Jackscrew Override		w/Hydraulic Override	
		psi	bar	psi	bar	Cu.In	Lts			Lbs	Kg	Lbs	Kg
12E2-05	1	150	10.3	150	10.3	84	1.4	112	51	123	57		
12E2-06		150	10.3	150	10.3	124	2.0	115	52	126	58		
12E2-07		132	9.1	113	7.8	170	2.8	121	55	132	61		
12E2-08		101	6.9	86	6.0	223	3.7	134	61	146	67		
12E2-09		79	5.5	68	4.7	285	4.7	143	65	154	71		
12E2-05	2	150	10.3	150	10.3	84	1.4	112	51	123	57		
12E2-06		150	10.3	150	10.3	124	2.0	115	52	126	58		
12E2-07		139	9.5	120	8.3	170	2.8	121	55	132	61		
12E2-08		106	7.3	92	6.3	223	3.7	134	61	146	67		
12E2-09		83	5.7	72	5.0	285	4.7	143	65	154	71		
12E2-06	3	150	10.3	150	10.3	124	2.0	121	55	132	61		
12E2-07		150	10.3	134	9.2	170	2.8	128	58	139	64		
12E2-08		116	8.0	102	7.0	223	3.7	141	64	152	70		
12E2-09		91	6.3	80	5.5	285	4.7	150	68	161	74		

18E2-06	1	150	10.3	150	10.3	146	2.4	172	78	185	84		
18E2-07		150	10.3	141	9.7	200	3.3	176	80	190	86		
18E2-08		125	8.6	108	7.4	266	4.4	194	88	207	94		
18E2-09		98	6.8	85	5.8	344	5.6	203	92	216	98		
18E2-10		79	5.5	69	4.7	429	7.0	223	101	236	107		
18E2-06	2	150	10.3	150	10.3	146	2.4	176	80	190	86		
18E2-07		150	10.3	147	10.1	200	3.3	181	82	194	88		
18E2-08		129	8.9	112	7.7	266	4.4	198	90	212	96		
18E2-09		102	7.0	88	6.1	344	5.6	207	94	220	100		
18E2-10		82	5.7	71	4.9	429	7.0	227	103	240	109		
18E2-06	3	150	10.3			146	2.4	181	82	194	88		
18E2-07		150	10.3	150	10.3	200	3.3	185	84	198	90		
18E2-08		142	9.8	125	8.6	266	4.4	203	92	216	98		
18E2-09		112	7.7	98	6.8	344	5.6	212	96	225	102		
18E2-10		90	6.2	79	5.5	429	7.0	231	105	245	111		

45E2-08	1	150	10.3	150	10.3	322	5.3	278	126	304	138		
45E2-09		150	10.3	150	10.3	417	6.8	287	130	313	142		
45E2-10		146	10.0	125	8.6	519	8.5	306	139	333	151		
45E2-12		101	7.0	87	6.0	750	12.3	344	156	370	168		
45E2-14		74	5.1	63	4.4	1020	16.7	401	182	428	194		
45E2-08	2	150	10.3	150	10.3	322	5.3	289	131	315	143		
45E2-09		150	10.3	150	10.3	417	6.8	298	135	324	147		
45E2-10		150	10.3	135	9.3	519	8.5	317	144	344	156		
45E2-12		108	7.4	93	6.4	750	12.3	355	161	381	173		
45E2-14		79	5.4	69	4.7	1020	16.7	412	187	439	199		
45E2-08	3	150	10.3	150	10.3	322	5.3	295	134	353	160		
45E2-09		150	10.3	150	10.3	417	6.8	304	138	362	164		
45E2-10		150	10.3	148	10.2	519	8.5	324	147	381	173		
45E2-12		117	8.1	103	7.1	750	12.3	362	164	419	190		
45E2-14		86	5.9	75	5.2	1020	16.7	419	190	476	216		
45E2-09	4	150	10.3	150	10.3	417	6.8	324	147	384	174		
45E2-10		150	10.3	150	10.3	519	8.5	344	156	403	183		
45E2-12		121	8.4	107	7.4	750	12.3	381	173	441	200		
45E2-14		89	6.1	79	5.4	1020	16.7	439	199	498	226		

11.2 - Spring Return Actuators - Cont.

Model	Spring #	Maximum Operating Pressure				Volume		Actuator Weight		Assembly Weight (approx)			
		Symmetrical		Canted		Rod End		Lbs	Kg	w/Jackscrew Override		w/Hydraulic Override	
		psi	bar	psi	bar	Cu.In	Lts			Lbs	Kg	Lbs	Kg
73E2-10	1	150	10.3	150	10.3	621	10.2	459	208	520	236	536	243
73E2-12		139	9.6	120	8.3	902	14.8	494	224	556	252	571	259
73E2-14		102	7.0	88	6.1	1227	20.1	545	247	606	275	622	282
73E2-16		78	5.4	67	4.6	1588	26.0	613	278	675	306	690	313
73E2-10	2	150	10.3	150	10.3	621	10.2	461	209	525	238	538	244
73E2-12		144	9.9	125	8.6	902	14.8	496	225	560	254	573	260
73E2-14		105	7.3	91	6.3	1227	20.1	547	248	611	277	624	283
73E2-16		80	5.5	70	4.8	1588	26.0	615	279	679	308	692	314
73E2-10	3	150	10.3	150	10.3	621	10.2	483	219	549	249	560	254
73E2-12		150	10.3	133	9.2	902	14.8	518	235	584	265	595	270
73E2-14		111	7.7	98	6.7	1227	20.1	569	258	635	288	646	293
73E2-16		85	5.9	75	5.1	1588	26.0	637	289	703	319	714	324
73E2-10	4	150	10.3	150	10.3	621	10.2	538	244	604	274	615	279
73E2-12		150	10.3	141	9.7	902	14.8	573	260	639	290	650	295
73E2-14		117	8.1	103	7.1	1227	20.1	624	283	690	313	701	318
73E2-16		90	6.2	79	5.4	1588	26.0	692	314	758	344	769	349

14E3-12	1	150	10.3	150	10.3	1071	17.6	747	339	842	382	855	388
14E3-14		150	10.3	137	9.5	1458	23.9	798	362	893	405	906	411
14E3-16		122	8.4	105	7.2	1890	31.0	869	394	963	437	977	443
14E3-18		96	6.6	83	5.7	2421	39.7	952	432	1047	475	1060	481
14E3-20		78	5.4	67	4.6	2978	48.8	1082	491	1177	534	1190	540
14E3-12	2	150	10.3	150	10.3	1071	17.6	769	349	869	394	877	398
14E3-14		150	10.3	142	9.8	1458	23.9	820	372	919	417	928	421
14E3-16		126	8.7	108	7.5	1890	31.0	891	404	990	449	999	453
14E3-18		99	6.8	86	5.9	2421	39.7	974	442	1074	487	1082	491
14E3-20		80	5.5	69	4.8	2978	48.8	1105	501	1204	546	1213	550
14E3-12	3	150	10.3	150	10.3	1071	17.6	789	358	888	403	897	407
14E3-14		150	10.3	148	10.2	1458	23.9	840	381	939	426	948	430
14E3-16		130	9.0	113	7.8	1890	31.0	910	413	1010	458	1019	462
14E3-18		103	7.1	89	6.1	2421	39.7	994	451	1093	496	1102	500
14E3-20		83	5.7	72	5.0	2978	48.8	1124	510	1224	555	1232	559
14E3-12	4	150	10.3	150	10.3	1071	17.6	816	370	930	422	924	419
14E3-14		150	10.3	150	10.3	1458	23.9	866	393	981	445	974	442
14E3-16		138	9.5	121	8.3	1890	31.0	937	425	1052	477	1045	474
14E3-18		109	7.5	95	6.6	2421	39.7	1021	463	1135	515	1129	512
14E3-20		88	6.1	77	5.3	2978	48.8	1151	522	1265	574	1259	571
14E3-12	5	150	10.3	150	10.3	1071	17.6	838	380	952	432	946	429
14E3-14		150	10.3	150	10.3	1458	23.9	888	403	1003	455	996	452
14E3-16		143	9.8	126	8.7	1890	31.0	959	435	1074	487	1067	484
14E3-18		113	7.8	99	6.8	2421	39.7	1043	473	1157	525	1151	522
14E3-20		91	6.3	80	5.5	2978	48.8	1173	532	1287	584	1281	581

11.2 - Spring Return Actuators - Cont.

Model	Spring #	Maximum Operating Pressure				Volume		Actuator Weight		Assembly Weight (approx)			
		Symmetrical		Canted		Rod End		Lbs	Kg	w/Jackscrew Override		w/Hydraulic Override	
		psi	bar	psi	bar	Cu.In	Lts			Lbs	Kg	Lbs	Kg
24E3-14	1	150	10.3	150	10.3	1831	30.0	1232	559	1387	629	1389	630
24E3-16		150	10.3	138	9.5	2387	39.2	1296	588	1451	658	1453	659
24E3-18		126	8.7	109	7.5	3059	50.2	1376	624	1530	694	1532	695
24E3-20		102	7.0	88	6.1	3750	61.5	1517	688	1671	758	1673	759
24E3-22		84	5.8	73	5.0	4561	74.8	1616	733	1770	803	1772	804
24E3-24		71	4.9	61	4.2	5452	89.4	1784	809	1938	879	1940	880
24E3-14	2	150	10.3	150	10.3	1831	30.0	1250	567	1407	638	1407	638
24E3-16		150	10.3	145	10.0	2387	39.2	1314	596	1470	667	1470	667
24E3-18		132	9.1	114	7.9	3059	50.2	1393	632	1550	703	1550	703
24E3-20		106	7.3	92	6.4	3750	61.5	1534	696	1691	767	1691	767
24E3-22		88	6.1	76	5.2	4561	74.8	1634	741	1790	812	1790	812
24E3-24		74	5.1	64	4.4	5452	89.4	1801	817	1958	888	1958	888
24E3-14	3	150	10.3	150	10.3	1831	30.0	1276	579	1468	666	1433	650
24E3-16		150	10.3	150	10.3	2387	39.2	1340	608	1532	695	1497	679
24E3-18		139	9.6	122	8.4	3059	50.2	1420	644	1612	731	1576	715
24E3-20		113	7.8	99	6.8	3750	61.5	1561	708	1753	795	1717	779
24E3-22		93	6.4	81	5.6	4561	74.8	1660	753	1852	840	1817	824
24E3-24		78	5.4	68	4.7	5452	89.4	1828	829	2019	916	1984	900
24E3-14	4	150	10.3	150	10.3	1831	30.0	1334	605	1528	693	1490	676
24E3-16		150	10.3	150	10.3	2387	39.2	1398	634	1592	722	1554	705
24E3-18		145	10.0	127	8.8	3059	50.2	1477	670	1671	758	1634	741
24E3-20		117	8.1	103	7.1	3750	61.5	1618	734	1812	822	1775	805
24E3-22		97	6.7	85	5.8	4561	74.8	1717	779	1911	867	1874	850
24E3-24		81	5.6	71	4.9	5452	89.4	1885	855	2079	943	2041	926
24E3-16	5	150	10.3	150	10.3	2387	39.2	1400	635	1596	724	1556	706
24E3-18		150	10.3	133	9.2	3059	50.2	1479	671	1675	760	1636	742
24E3-20		122	8.4	108	7.4	3750	61.5	1620	735	1817	824	1777	806
24E3-22		101	6.9	89	6.1	4561	74.8	1720	780	1916	869	1876	851
24E3-24		84	5.8	75	5.1	5452	89.4	1887	856	2083	945	2044	927

11.2 - Spring Return Actuators - Cont.

Model	Spring #	Maximum Operating Pressure				Volume		Actuator Weight		Assembly Weight (approx)			
		Symmetrical		Canted		Rod End		Lbs	Kg	w/Jackscrew Override		w/Hydraulic Override	
		psi	bar	psi	bar	Cu.In	Lts			Lbs	Kg	Lbs	Kg
45E3-18	1	150	10.3	150	10.3	3722	61.0	2169	984			2418	1097
45E3-20		150	10.3	134	9.2	4584	75.2	2306	1046			2555	1159
45E3-22		128	8.8	110	7.6	5591	91.7	2410	1093			2659	1206
45E3-24		107	7.4	93	6.4	6676	109.5	2579	1170			2829	1283
45E3-28		79	5.4	68	4.7	9074	148.8	3007	1364			3256	1477
45E3-18	2	150	10.3	150	10.3	3722	61.0	2220	1007			2469	1120
45E3-20		150	10.3	138	9.5	4584	75.2	2357	1069			2606	1182
45E3-22		132	9.1	114	7.9	5591	91.7	2460	1116			2709	1229
45E3-24		111	7.6	96	6.6	6676	109.5	2630	1193			2879	1306
45E3-28		81	5.6	70	4.8	9074	148.8	3058	1387			3307	1500
45E3-18	3	150	10.3	150	10.3	3722	61.0	2363	1072			2612	1185
45E3-20		150	10.3	147	10.2	4584	75.2	2500	1134			2749	1247
45E3-22		139	9.6	122	8.4	5591	91.7	2604	1181			2853	1294
45E3-24		117	8.1	102	7.0	6676	109.5	2773	1258			3023	1371
45E3-28		86	5.9	75	5.2	9074	148.8	3201	1452			3450	1565
45E3-18	4	150	10.3	150	10.3	3722	61.0	2474	1122			2723	1235
45E3-20		150	10.3	150	10.3	4584	75.2	2610	1184			2859	1297
45E3-22		144	9.9	126	8.7	5591	91.7	2714	1231			2963	1344
45E3-24		120	8.3	105	7.3	6676	109.5	2884	1308			3133	1421
45E3-28		88	6.1	77	5.3	9074	148.8	3311	1502			3560	1615
45E3-18	5	150	10.3	150	10.3	3722	61.0	2535	1150			2784	1263
45E3-20		150	10.3	150	10.3	4584	75.2	2672	1212			2921	1325
45E3-22		149	10.2	131	9.0	5591	91.7	2776	1259			3025	1372
45E3-24		125	8.6	110	7.6	6676	109.5	2945	1336			3194	1449
45E3-28		91	6.3	80	5.5	9074	148.8	3373	1530			3622	1643
10E4-22	1	150	10.3	150	10.3	6875	112.8	4153	1884			4429	2009
10E4-24		150	10.3	150	10.3	8173	134.0	4330	1964			4605	2089
10E4-28		143	9.8	123	8.4	11049	181.2	4815	2184			5090	2309
10E4-32		109	7.5	94	6.4	14589	239.3	5370	2436			5646	2561
10E4-36		86	5.9	74	5.1	18327	300.6	6078	2757			6354	2882
10E4-22	2	150	10.3	150	10.3	6875	112.8	4297	1949			4572	2074
10E4-24		150	10.3	150	10.3	8173	134.0	4473	2029			4749	2154
10E4-28		147	10.1	126	8.7	11049	181.2	4958	2249			5234	2374
10E4-32		112	7.7	97	6.7	14589	239.3	5514	2501			5789	2626
10E4-36		88	6.1	76	5.3	18327	300.6	6221	2822			6497	2947
10E4-22	3	150	10.3	150	10.3	6875	112.8	4594	2084			4870	2209
10E4-24		150	10.3	150	10.3	8173	134.0	4771	2164			5046	2289
10E4-28		150	10.3	135	9.3	11049	181.2	5256	2384			5531	2509
10E4-32		119	8.2	103	7.1	14589	239.3	5811	2636			6087	2761
10E4-36		94	6.5	82	5.6	18327	300.6	6519	2957			6795	3082
10E4-22	4	150	10.3	150	10.3	6875	112.8	4793	2174			5068	2299
10E4-24		150	10.3	150	10.3	8173	134.0	4969	2254			5245	2379
10E4-28		150	10.3	141	9.7	11049	181.2	5454	2474			5730	2599
10E4-32		123	8.5	108	7.4	14589	239.3	6010	2726			6285	2851
10E4-36		97	6.7	85	5.9	18327	300.6	6717	3047			6993	3172

12.0 MODULE WEIGHTS

MODULE WEIGHTS (APPROX), Lbs																							
Model	Rated Torq. Nm	Torque Module	Pressure Modules Size, Inch															Spring Modules					
			5	6	7	8	9	10	12	14	16	18	20	22	24	28	32	36	1	2	3	4	5
12 E2	1,200	33	26	29	35	49	57												53	53	60		
18 E2	1,800	55		35	40	57	66	86											82	86	90		
45 E2	4,500	84				60	68	88	126	183									134	146	152	172	
73 E2	7,300	146						99	134	185	254								214	216	238	293	
14 E3	14,000	236							150	201	271	355	485						362	384	403	430	452
24 E3	24,000	428								229	293	373	514	613	780				575	593	619	677	679
45 E3	45,000	666										439	575	679	849	1276			1065	1116	1259	1369	1431
10 E4	100,000	1312													780	957	1442	1997	2705	2061	2205	2502	2701

MODULE WEIGHTS (APPROX), Kg																							
Model	Rated Torq. Nm	Torque Module	Pressure Modules Size, Inch															Spring Modules					
			5	6	7	8	9	10	12	14	16	18	20	22	24	28	32	36	1	2	3	4	5
12 E2	1,200	15	12	13	16	22	26												24	24	27		
18 E2	1,800	25		16	18	26	30	39											37	39	41		
45 E2	4,500	38				27	31	40	57	83									61	66	69	78	
73 E2	7,300	66						45	61	84	115								97	98	108	133	
14 E3	14,000	107							68	91	123	161	220						164	174	183	195	205
24 E3	24,000	194								104	133	169	233	278	354				261	269	281	307	308
45 E3	45,000	302										199	261	308	385	579			483	506	571	621	649
10 E4	100,000	595													354	434	654	906	1227	935	1000	1135	1225

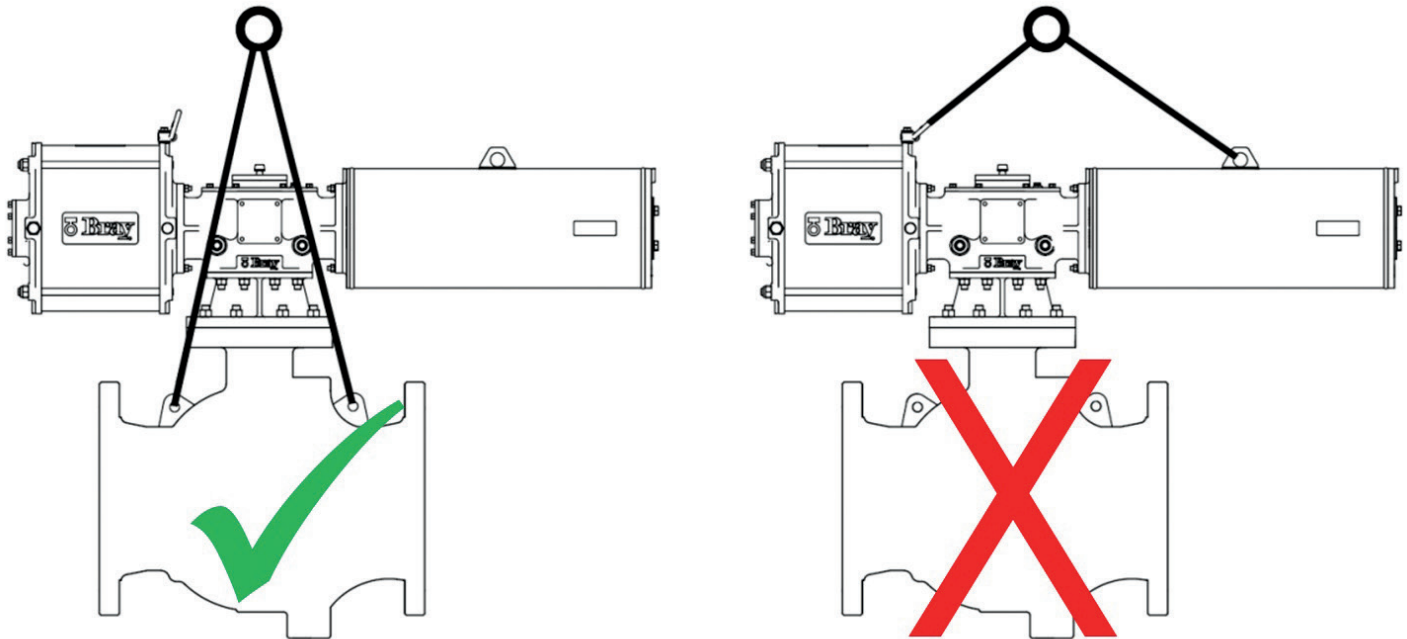

Actuator lifting lugs are only for lifting the stand-alone actuator, not for the complete assembly

13.0 SERIES 98 DIMENSIONS

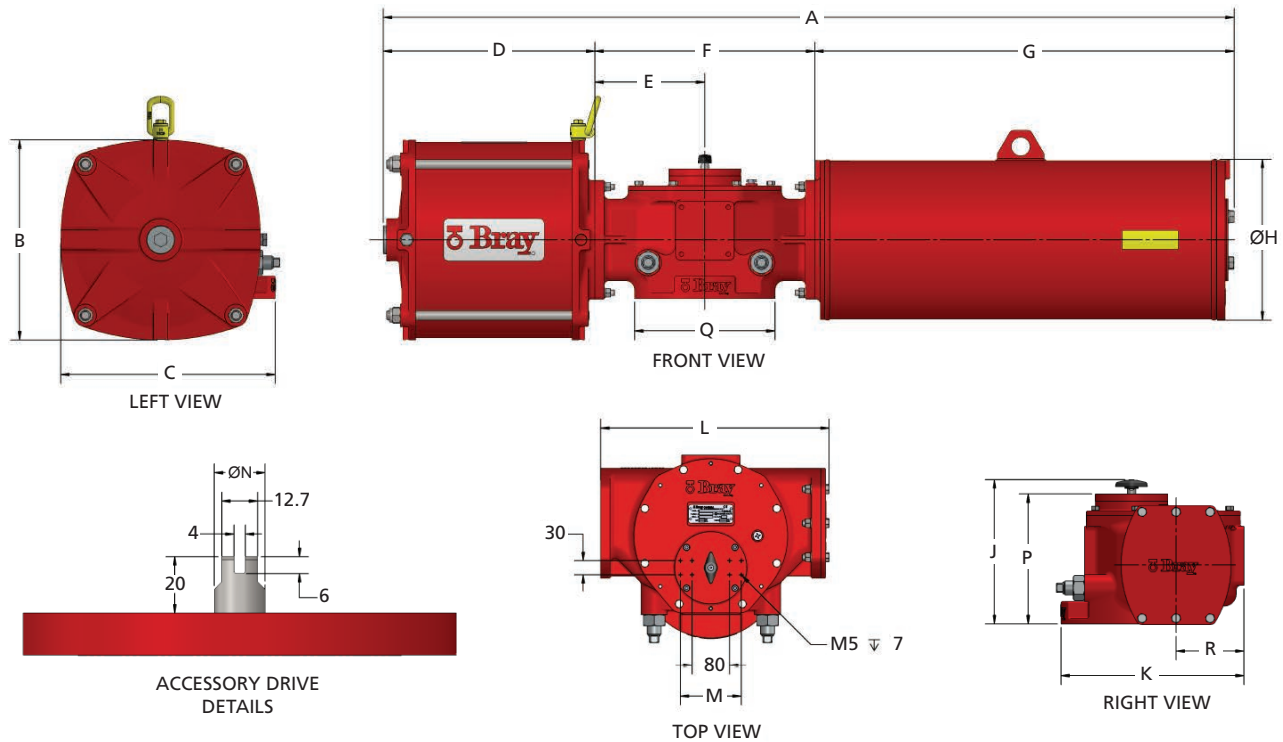

Series 98 Max Dimensions, inch

Model	ISO Base	A	B	C	D	E	F	G	H	J	K	L	M	N	P	Q	R
12E2	F12/F07	35.2	9.8	9.8	10.1	4.6	9.3	15.7	7.1	7.3	6.8	9.8	--	0.6	6.1	4.4	3.0
18E2	F12	42.4	10.8	10.8	12.2	5.5	11.1	19.1	8.1	8.7	8.7	11.7	--	0.6	7.4	4.4	4.0
45E2	F16/F12	52.8	14.8	14.8	14.2	6.3	12.5	26.2	9.4	9.7	9.4	13.1	--	0.7	8.5	7.7	3.8
73E2	F16/F12	60.1	16.8	16.8	15.8	7.9	15.8	28.5	12.8	11.8	11.3	16.5	--	0.7	9.8	7.8	5.1
14E3	F25/16	72.6	21.3	21.3	18.8	9.3	18.5	35.3	13.5	12.1	15.4	19.6	5.1	0.7	10.9	11.8	5.7
24E3	F30/25	90.0	25.1	25.1	21.9	11.5	22.9	45.2	15.6	14.3	19.3	23.8	5.1	1.0	13.1	13.8	7.3
45E3	F35/30	113.3	33.3	33.3	25.8	14.3	28.6	58.9	18.7	15.3	22.8	29.5	5.1	1.0	14.1	16.3	8.3
10E4	F40/F35	138.1	41.7	38.0	32.8	17.8	35.5	69.8	21.9	18.9	28.3	37.6	5.1	1.0	17.8	18.7	11.3

Series 98 Max Dimensions, mm

Model	ISO Base	A	B	C	D	E	F	G	H	J	K	L	M	N	P	T	U
12E2	F12/F07	893	248	248	257	118	236	400	180	185	173	248	--	15	155	113	76
18E2	F12	1077	274	274	309	141	281	486	205	222	220	296	--	15	189	113	102
45E2	F16/F12	1342	376	376	360	159	318	664	240	246	240	333	--	18	216	195	96
73E2	F16/F12	1526	427	427	400	201	402	723	326	300	288	420	--	18	249	197	129
14E3	F25/16	1843	542	542	477	235	470	896	342	307	390	498	130	18	276	300	145
24E3	F30/25	2287	638	638	556	291	582	1148	397	364	491	605	130	25	334	350	186
45E3	F35/30	2877	845	845	656	363	726	1495	476	388	580	750	130	25	357	415	212
10E4	F40/F35	3507	1060	964	832	451	902	1773	556	481	720	955	130	25	451	475	286

Note: Refer ES drawings for dimensions of specific models

CYLINDER PORT SIZE

Cylinder Size	UP TO 5"	6" - 9"	10"	12" - 16"	18" - 24"	28" - 36"
Ports, NPT	1/4"	3/8"	1/2"	3/4"	1"	1.5"

13.1 SERIES 98 DIMENSIONS - BOLTING PATTERN

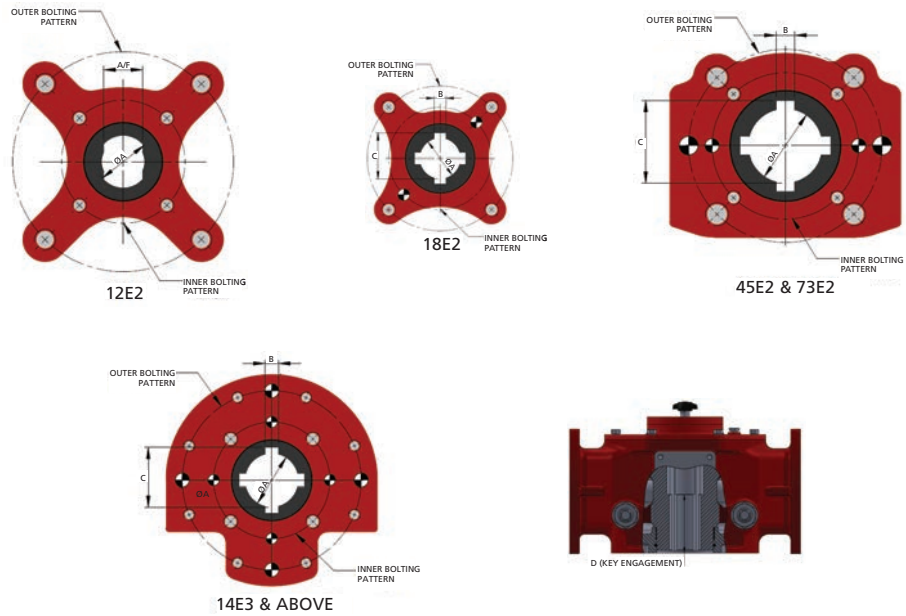

Model	Max Stem Height	Outer Bolting Pattern						Inner Bolting Pattern					
		ISO Base	Thread Size	Bolt Circle	No. of Bolt Holes	Dowel Hole Size	No. of Dowel Holes	ISO Base	Tapped Hole	Bolt Circle	No. of Tapped Holes	Dowel	No. of Dowel Holes
12E2	130	F12	M12 x 15mm	125	4	–	–	F07	M8 x 12mm	70	4	–	–
18E2	163	F12	M12 x 18mm	125	4	–	–	–	–	88	–	10.1 +0.05/0, x 10mm	2
45E2	183	F16	M20 x 30mm	165	4	16.1 +0.05/0 x 15mm	2	F12	M12 x 18mm	125	4	12.1 +0.05/0 x 13mm	2
73E2	216	F16	M20 x 30mm	165	4	16.1 +0.05/0 x 15mm	2	F12	M12 x 18mm	125	4	12.1 +0.05/0 x 13mm	2
14E3	240	F25	M16 x 24mm	254	8	20.1 +0.05/0 x 17.5mm	4	F16	M20 x 30mm	165	4	16.1 +0.05/0 x 15mm	4
24E3	295	F30	M20 x 30mm	298	8	20.1 +0.05/0 x 17.5mm	4	F25	M16 x 24mm	254	8	20.1 +0.05/0 x 17.5mm	4
45E3	318	F35	M30 x 45mm	356	8	30.1 +0.05/0 x 27mm	4	F30	M20 x 30mm	298	8	20.1 +0.05/0 x 17.5mm	4
10E4	402	F40	M36 x 54mm	406	8	36.1 +0.05/0 x 36mm	4	F35 OPTION	M30 x 45mm	356	8	30.1 +0.05/0 x 27mm	4

13.2 SERIES 98 DIMENSIONS - BORE

Model	Bore 1 (Standard)						Bore 2						Bore 3						
	Drive	A	A/F	B	C	D	Drive	A	A/F	B	C	D	Drive	A	A/F	B	C	D	
12E2	Double D	30 +0.18/+0.10	22 +0.08/+0.03	–	–	50													
18E2	Key	35 +0.18/+0.10	–	10.05 +0.05/0	39.4 +0.3/0	163	Double D	30 +0.18/+0.10	22 +0.08/+0.03	–	–	53							
45E2	Key	50 +0.18/+0.10	–	12.05 +0.05/0	54.5 +0.3/0	183	Key	35 +0.18/+0.10	–	10.05 +0.05/0	39.4 +0.3/0	65							
73E2	Key	63.5 +0.18/+0.10	–	15.93 +0.08/0	70.6 +0.3/0	216	Key	50 +0.18/+0.10	–	12.05 +0.05/0	54.5 +0.3/0	68							
14E3	Key	76.2 +0.18/+0.10	–	19.1 +0.08/0	84.7 +0.3/0	240	Key	63.5 +0.18/+0.10	–	15.93 +0.08/0	70.6 +0.3/0	119							
24E3	Key	114.3 +0.18/+0.10	–	25.45 +0.08/0	122.6 +0.3/0	295	Key	101.6 +0.18/+0.10	–	25.45 +0.08/0	109.7 +0.3/0	162	Key	88.9 +0.18/+0.10	–	22.28 +0.08/0	95.7 +0.3/0	154	
45E3	Key	152.4 +0.18/+0.10	–	38.18 +0.1/0	162.9 +0.3/0	318	Key	127 +0.18/+0.10	–	31.85 +0.1/0	136.3 +0.3/0	175							
10E4	Key	177.8 +0.18/+0.10	–	44.5 +0.15/0.05	194.3 +0.3/0	402	Key	152.4 +0.18/+0.10	–	38.18 +0.1/0	162.9 +0.3/0	172							

14.0 SERIES 98 GENERAL SPECIFICATIONS AND FEATURES

GENERAL SPECIFICATIONS												
RANGE												
Model	ISO Mounting Base	Rated Torque		Spring End Torque Nm		Spring End Torque Lb-in		Maximum Stem Acceptance Diameter		Maximum Stem Height	Over Travel (on either side)	
		Nm	Lb-in	Min	Max	Min	Max	mm	inch	mm	± degrees	
12 E2	F07/F12	1,200	10,621	310	660	2,744	5,842	22 A/F	0.87 A/F	130	5	
18 E2	F12	1,800	15,932	530	1,035	4,691	9,161	35.0	1.38	163	5	
45 E2	F12/F16	4,500	39,830	1,070	2,675	9,471	23,676	50.0	1.97	183	5	
73 E2	F12/F16	7,300	64,612	2,130	4,280	18,853	37,882	63.5	2.50	216	5	
14 E3	F16/F25	14,000	123,914	3,485	7,845	30,846	69,436	76.2	3.00	240	5	
24 E3	F25/F30	24,000	212,424	6,555	15,150	58,018	134,093	114.3	4.50	295	3	
45 E3	F30/F35	45,000	398,295	11,950	25,595	105,769	226,541	152.4	6.00	318	3	
10 E4	F35/F40	100,000	885,100	25,226	50,306	223,275	445,261	177.8	7.00	402	3	
CONFIGURATIONS												
DA	Double Acting- Single Cylinder											
DD	Double Acting- Dual Cylinders											
SR-CW	Spring Return- Fail CW											
SR-CCW	Spring Return- Fail CCW											
OPERATING CONDITIONS												
Pressure Range	40 - 150 psi											
Media	Dry Compressed Air / Inert / Natural Gas							Contact factory for other media				
Temperature Range - Standard Options	Standard : -20°F to 200°F (-29°C to 93°C)											
	High Temp : Up to 300°F (149°C)							Contact factory for extended ranges				
	Low Temp : Down to -50°F (-46°C)											
COMPLIANCES												
Torque Base	Mounting dimensions options per ISO 5211: 2001(E) or MSS SP-101-1989											
Accessories	Shaft Driven Accessories Mounting as per NAMUR-VDE											
Testing	In accordance with EN 15714-3:2009											
Ingress Protection	IP67M per IEC 60529											
Safety	ATEX, SIL 3, PED											

14.1 SERIES 98 SEAL KITS AND REPAIR KITS

SEAL KIT & REPAIR KIT (Standard)									
MODEL	KIT	TORQUE MODULE	PRESSURE MODULE					SPRING MODULE	
12E2			5	6	7	8	9		
	Seal Kit	98-T10B-21900-560	98-P05B-21900-560	98-P06B-21900-560	98-P07B-21900-560	98-P08B-21900-560	98-P09B-21900-560		98-S00B-21900-560
	Repair Kit	98-T10B-21901-560	98-P05B-21901-560	98-P06B-21901-560	98-P07B-21901-560	98-P08B-21901-560	98-P09B-21901-560		98-S00B-21901-560
18E2			6	7	8	9	10		
	Seal Kit	98-T12C-21900-560	98-P06C-21900-560	98-P07C-21900-560	98-P08D-21900-560	98-P09D-21900-560	98-P10D-21900-560		98-S00B-21900-560
	Repair Kit	98-T12C-21901-560	98-P06C-21901-560	98-P07C-21901-560	98-P08D-21901-560	98-P09D-21901-560	98-P10D-21901-560		98-S00C-21901-560
45E2			8	9	10	12	14		
	Seal Kit	98-T15D-21900-560	98-P08D-21900-560	98-P09D-21900-560	98-P10D-21900-560	98-P12D-21900-560	98-P14D-21900-560		98-S00D-21900-560
	Repair Kit	98-T15D-21901-560	98-P08D-21901-560	98-P09D-21901-560	98-P10D-21901-560	98-P12D-21901-560	98-P14D-21901-560		98-S00D-21901-560
73E2			10	12	14	16			
	Seal Kit	98-T17E-21900-560	98-P10E-21900-560	98-P12E-21900-560	98-P14E-21900-560	98-P16E-21900-560			98-S00E-21900-560
	Repair Kit	98-T17E-21901-560	98-P10E-21901-560	98-P12E-21901-560	98-P14E-21901-560	98-P16E-21901-560			98-S00E-21901-560
14E3			12	14	16	18	20		
	Seal Kit	98-T18F-21900-560	98-P12F-21900-560	98-P14F-21900-560	98-P16F-21900-560	98-P18F-21900-560	98-P20F-21900-560		98-S00F-21900-560
	Repair Kit	98-T18F-21901-560	98-P12F-21901-560	98-P14F-21901-560	98-P16F-21901-560	98-P18F-21901-560	98-P20F-21901-560		98-S00F-21901-560
24E3			14	16	18	20	22	24	
	Seal Kit	98-T21G-21900-560	98-P14G-21900-560	98-P16G-21900-560	98-P18G-21900-560	98-P20G-21900-560	98-P22G-21900-560	98-P24G-21900-560	98-S00G-21900-560
	Repair Kit	98-T21G-21901-560	98-P14G-21901-560	98-P16G-21901-560	98-P18G-21901-560	98-P20G-21901-560	98-P22G-21901-560	98-P24G-21901-560	98-S00G-21901-560
45E3			18	20	22	24	28		
	Seal Kit	98-T23H-21900-560	98-P18H-21900-560	98-P20H-21900-560	98-P22H-21900-560	98-P24H-21900-560	98-P28H-21900-560		98-S00H-21900-560
	Repair Kit	98-T23H-21901-560	98-P18H-21901-560	98-P20H-21901-560	98-P22H-21901-560	98-P24H-21901-560	98-P28H-21901-560		98-S00H-21901-560
10E4			22	24	28	32	36		
	Seal Kit	98-T24J-21900-560	98-P22J-21900-560	98-P24J-21900-560	98-P28J-21900-560	98-P32J-21900-560	98-P36J-21900-560		98-S00J-21900-560
	Repair Kit	98-T24J-21901-560	98-P22J-21901-560	98-P24J-21901-560	98-P28J-21901-560	98-P32J-21901-560	98-P36J-21901-560		98-S00J-21901-560

SEAL KIT & REPAIR KIT (Low Temperature)									
MODEL	KIT	TORQUE MODULE	PRESSURE MODULE					SPRING MODULE	
12E2			5	6	7	8	9		
	Seal Kit	98-T10B-21900-5XA	98-P05B-21900-5XA	98-P06B-21900-5XA	98-P07B-21900-5XA	98-P08B-21900-5XA	98-P09B-21900-5XA		98-S00B-21900-5XA
	Repair Kit	98-T10B-21901-5XA	98-P05B-21901-5XA	98-P06B-21901-5XA	98-P07B-21901-5XA	98-P08B-21901-5XA	98-P09B-21901-5XA		98-S00B-21901-5XA
18E2			6	7	8	9	10		
	Seal Kit	98-T12C-21900-5XA	98-P06C-21900-5XA	98-P07C-21900-5XA	98-P08D-21900-5XA	98-P09D-21900-5XA	98-P10D-21900-5XA		98-S00B-21900-5XA
	Repair Kit	98-T12C-21901-5XA	98-P06C-21901-5XA	98-P07C-21901-5XA	98-P08D-21901-5XA	98-P09D-21901-5XA	98-P10D-21901-5XA		98-S00C-21901-5XA
45E2			8	9	10	12	14		
	Seal Kit	98-T15D-21900-5XA	98-P08D-21900-5XA	98-P09D-21900-5XA	98-P10D-21900-5XA	98-P12D-21900-5XA	98-P14D-21900-5XA		98-S00D-21900-5XA
	Repair Kit	98-T15D-21901-5XA	98-P08D-21901-5XA	98-P09D-21901-5XA	98-P10D-21901-5XA	98-P12D-21901-5XA	98-P14D-21901-5XA		98-S00D-21901-5XA
73E2			10	12	14	16			
	Seal Kit	98-T17E-21900-5XA	98-P10E-21900-5XA	98-P12E-21900-5XA	98-P14E-21900-5XA	98-P16E-21900-5XA			98-S00E-21900-5XA
	Repair Kit	98-T17E-21901-5XA	98-P10E-21901-5XA	98-P12E-21901-5XA	98-P14E-21901-5XA	98-P16E-21901-5XA			98-S00E-21901-5XA
14E3			12	14	16	18	20		
	Seal Kit	98-T18F-21900-5XA	98-P12F-21900-5XA	98-P14F-21900-5XA	98-P16F-21900-5XA	98-P18F-21900-5XA	98-P20F-21900-5XA		98-S00F-21900-5XA
	Repair Kit	98-T18F-21901-5XA	98-P12F-21901-5XA	98-P14F-21901-5XA	98-P16F-21901-5XA	98-P18F-21901-5XA	98-P20F-21901-5XA		98-S00F-21901-5XA
24E3			14	16	18	20	22	24	
	Seal Kit	98-T21G-21900-5XA	98-P14G-21900-5XA	98-P16G-21900-5XA	98-P18G-21900-5XA	98-P20G-21900-5XA	98-P22G-21900-5XA	98-P24G-21900-5XA	98-S00G-21900-5XA
	Repair Kit	98-T21G-21901-5XA	98-P14G-21901-5XA	98-P16G-21901-5XA	98-P18G-21901-5XA	98-P20G-21901-5XA	98-P22G-21901-5XA	98-P24G-21901-5XA	98-S00G-21901-5XA
45E3			18	20	22	24	28		
	Seal Kit	98-T23H-21900-5XA	98-P18H-21900-5XA	98-P20H-21900-5XA	98-P22H-21900-5XA	98-P24H-21900-5XA	98-P28H-21900-5XA		98-S00H-21900-5XA
	Repair Kit	98-T23H-21901-5XA	98-P18H-21901-5XA	98-P20H-21901-5XA	98-P22H-21901-5XA	98-P24H-21901-5XA	98-P28H-21901-5XA		98-S00H-21901-5XA
10E4			22	24	28	32	36		
	Seal Kit	98-T24J-21900-5XA	98-P22J-21900-5XA	98-P24J-21900-5XA	98-P28J-21900-5XA	98-P32J-21900-5XA	98-P36J-21900-5XA		98-S00J-21900-5XA
	Repair Kit	98-T24J-21901-5XA	98-P22J-21901-5XA	98-P24J-21901-5XA	98-P28J-21901-5XA	98-P32J-21901-5XA	98-P36J-21901-5XA		98-S00J-21901-5XA

SEAL KIT & REPAIR KIT (High Temperature)									
MODEL	KIT	TORQUE MODULE	PRESSURE MODULE						SPRING MODULE
12E2			5	6	7	8	9		
	Seal Kit	98-T10B-21900-5XB	98-P05B-21900-5XB	98-P06B-21900-5XB	98-P07B-21900-5XB	98-P08B-21900-5XB	98-P09B-21900-5XB		98-S00B-21900-5XB
	Repair Kit	98-T10B-21901-5XB	98-P05B-21901-5XB	98-P06B-21901-5XB	98-P07B-21901-5XB	98-P08B-21901-5XB	98-P09B-21901-5XB		98-S00B-21901-5XB
18E2			6	7	8	9	10		
	Seal Kit	98-T12C-21900-5XB	98-P06C-21900-5XB	98-P07C-21900-5XB	98-P08D-21900-5XB	98-P09D-21900-5XB	98-P10D-21900-5XB		98-S00B-21900-5XB
	Repair Kit	98-T12C-21901-5XB	98-P06C-21901-5XB	98-P07C-21901-5XB	98-P08D-21901-5XB	98-P09D-21901-5XB	98-P10D-21901-5XB		98-S00C-21901-5XB
45E2			8	9	10	12	14		
	Seal Kit	98-T15D-21900-5XB	98-P08D-21900-5XB	98-P09D-21900-5XB	98-P10D-21900-5XB	98-P12D-21900-5XB	98-P14D-21900-5XB		98-S00D-21900-5XB
	Repair Kit	98-T15D-21901-5XB	98-P08D-21901-5XB	98-P09D-21901-5XB	98-P10D-21901-5XB	98-P12D-21901-5XB	98-P14D-21901-5XB		98-S00D-21901-5XB
73E2			10	12	14	16			
	Seal Kit	98-T17E-21900-5XB	98-P10E-21900-5XB	98-P12E-21900-5XB	98-P14E-21900-5XB	98-P16E-21900-5XB			98-S00E-21900-5XB
	Repair Kit	98-T17E-21901-5XB	98-P10E-21901-5XB	98-P12E-21901-5XB	98-P14E-21901-5XB	98-P16E-21901-5XB			98-S00E-21901-5XB
14E3			12	14	16	18	20		
	Seal Kit	98-T18F-21900-5XB	98-P12F-21900-5XB	98-P14F-21900-5XB	98-P16F-21900-5XB	98-P18F-21900-5XB	98-P20F-21900-5XB		98-S00F-21900-5XB
	Repair Kit	98-T18F-21901-5XB	98-P12F-21901-5XB	98-P14F-21901-5XB	98-P16F-21901-5XB	98-P18F-21901-5XB	98-P20F-21901-5XB		98-S00F-21901-5XB
24E3			14	16	18	20	22	24	
	Seal Kit	98-T21G-21900-5XB	98-P14G-21900-5XB	98-P16G-21900-5XB	98-P18G-21900-5XB	98-P20G-21900-5XB	98-P22G-21900-5XB	98-P24G-21900-5XB	98-S00G-21900-5XB
	Repair Kit	98-T21G-21901-5XB	98-P14G-21901-5XB	98-P16G-21901-5XB	98-P18G-21901-5XB	98-P20G-21901-5XB	98-P22G-21901-5XB	98-P24G-21901-5XB	98-S00G-21901-5XB
45E3			18	20	22	24	28		
	Seal Kit	98-T23H-21900-5XB	98-P18H-21900-5XB	98-P20H-21900-5XB	98-P22H-21900-5XB	98-P24H-21900-5XB	98-P28H-21900-5XB		98-S00H-21900-5XB
	Repair Kit	98-T23H-21901-5XB	98-P18H-21901-5XB	98-P20H-21901-5XB	98-P22H-21901-5XB	98-P24H-21901-5XB	98-P28H-21901-5XB		98-S00H-21901-5XB
10E4			22	24	28	32	36		
	Seal Kit	98-T24J-21900-5XB	98-P22J-21900-5XB	98-P24J-21900-5XB	98-P28J-21900-5XB	98-P32J-21900-5XB	98-P36J-21900-5XB		98-S00J-21900-5XB
	Repair Kit	98-T24J-21901-5XB	98-P22J-21901-5XB	98-P24J-21901-5XB	98-P28J-21901-5XB	98-P32J-21901-5XB	98-P36J-21901-5XB		98-S00J-21901-5XB

15.0 HYDRAULIC OVERRIDE

Hydraulic overrides on S98 actuators provide low effort, high thrust in a compact size for manually operating the actuator. The hydraulic override cylinders are single acting on the SR models and double acting on the DA models of the Actuators. These are available on Models 73E2 through 10E4.

The hydraulic override consists of a power pack with a hand operated high pressure pump and oil reservoir connected by tubing to the hydraulic override cylinder. The hydraulic cylinder is mounted on the Spring Module end thrust base on SR models and on the Torque Module flange on the DA models.

The hydraulic override cylinders are designed for 3,000 psi max working pressure and provide adequate thrust to output the required valve torque. The operating pressure required is set on the hand pump assembly through a built-in relief valve.

15.1 Installation

Series 98 standard actuators with hydraulic overrides are shipped pre-assembled with the cylinder, hand pump, bypass valves and tubing complete. The hand pump unit is selected, factory installed and the hydraulic pressure valve set per the application. No additional customer installation/adjustment is usually required.

Actuators in service, without this override option, can be retrofitted with the override kit as described below.

15.1.1 Installing Hydraulic Override on Spring Return Actuators

1. Disconnect air pressure and electrical power from actuator.
2. In fail safe position of the actuator, remove the end cover plate retaining the O-ring on the End Cap.
3. Firmly thread the studs (10) supplied with the override mounting kit, into the thrust base. With the piston rod fully retracted, insert the Hydraulic Cylinder into the Spring Module positioning the air venting plug at the top.

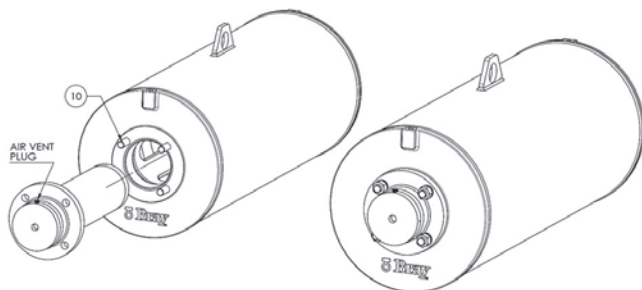

4. Secure the cylinder flange on the thrust base of the Spring Module with the spring washers and nuts from the override mounting kit.
5. Thread in the hydraulic connector into the cylinder port (if not already fitted into the cylinder). Use a commercial hydraulic fitting thread sealant (Loctite 542 or equivalent).
6. Fit a 3-way valve, rated for 150 psi (10.3 bar) working pressure, to the pneumatic module's port (Refer to Figure A). Turn the valve to venting position so that the pneumatic cylinder's port is connected to atmosphere.
7. Fit the hydraulic hand pump assembly bracket on the rear accessories mounting pad of the Torque Module with the 4 bolts supplied in the kit. Tube the cylinder port to the pump outlet port, as in Figure A. The standard mounting, as shown, is for the actuator in horizontal orientation. Special brackets for other orientations of the actuator can be supplied upon request.
8. On the Tee fitting at the pump outlet, remove the plug and install a suitable pressure gage (0-4000psi).

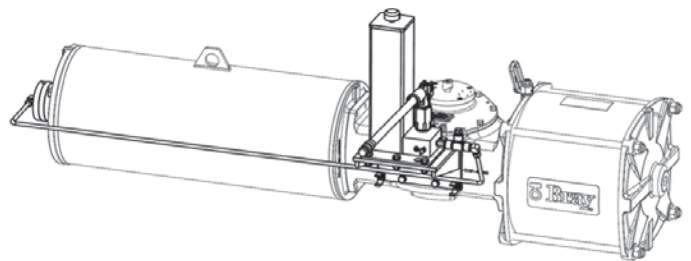

9. Remove the filler-breather cap and fill the reservoir till about 1-2" from the top with hydraulic fluid (ISO 32 grade for standard temperature service). Install the breather cap on the reservoir (do not substitute the breather cap with a plug). Stroke the pump a few times with the pressure release valve on the pump open, to bleed air out of pump.
10. Lightly loosen the air vent screw on the cylinder flange to bleed off air from the hydraulic lines. Close the pressure release valve on the pump and stroke the hydraulic pump till the pressure builds up. Tighten the vent plug when no more air bubbles bleed out. The piston rod advances to press against the Spring Rod's end face and the thrust from the hydraulic pressure effects the override function.
11. Note the maximum hydraulic pressure setting for the actuator model (refer to the SR Hydraulic MOP table). Check the hydraulic pressure on the gage at the end of the actuator's stroke. Refer to the hand pump service manual and adjust the overload valve setting on the pump to the MOP.

MOP for SR Hydraulic Overrides						
Model	MOP	Spring Number				
		1	2	3	4	5
73 E2	psi	1585	1880	2425	2740	
	bar	109	130	167	189	
14 E3	psi	1325	1520	1770	2260	2705
	bar	91	105	122	156	187
24 E3	psi	1290	1530	1950	2260	2595
	bar	89	105	134	156	179
45 E3	psi	1185	1415	1615	1855	2155
	bar	82	98	111	128	149
10 E4	psi	2465	3005	3630	4400	
	bar	170	207	250	303	

15.1.2 Operation - Spring Return Hydraulic Override

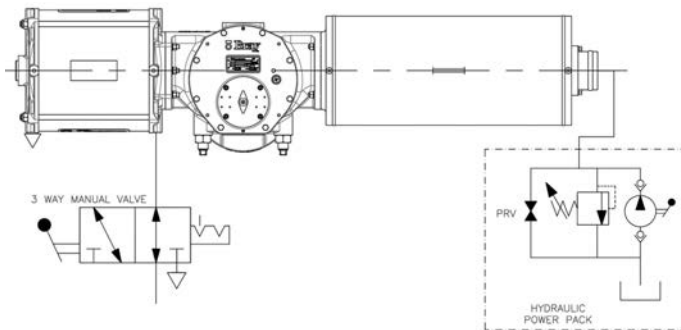

- To operate the override, turn the 3/2 way valve on the pressure module to vent the cylinder port to atmosphere and Close the pressure release valve (PRV) on the hand pump manifold. Operating the Hand Pump on the power pack extends the Hydraulic cylinder's piston rod and pushes the Spring Rod while compressing the spring and operates the actuator manually.
- Opening the pressure release valve relieves the hydraulic pressure to reservoir. The spring returns the piston rod of override cylinder to retracted position and the actuator to fail safe position.
- To restore normal pneumatic operation, turn the pressure release valve to full Open and switch the 3/2 way valve on pneumatic cylinder, to connect the cylinder port to the air supply pressure.

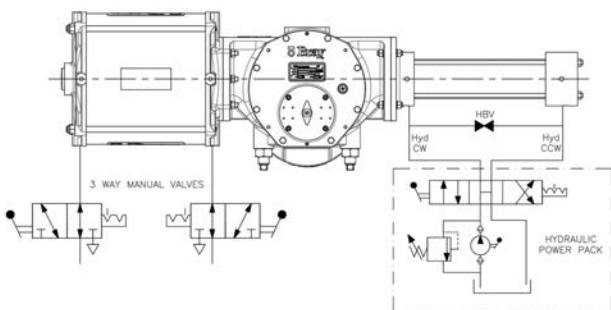

15.2 Installing Hydraulic Override on DA Actuator

- Turn the actuator so that the guide block is at the cover end side of the Torque Module and ensure it stays in this position after disconnecting air pressure and electrical power from actuator.
- Remove the DA cover from the torque module and mount the DA hydraulic override cylinder assembly with the hardware supplied in mounting kit. Make sure to install the O-ring on the mounting flange.
- Remove the hydraulic cylinder's tie rod nuts and the end cap without disturbing the cylinder barrel. With a suitable socket/tube spanner located on the hex head at the piston end, thread and tighten the piston rod into the threading on Guide Block (inside the Torque Module). Refer to the table below for tightening torque.

Hydraulic Piston Rod Tightening Torque		
Model	Torque	
	Lb-ft	Nm
73 E2	148	200
14 E3	184	250
24 E3	184	250
45 E3	258	350
10 E4	332	450

- Replace the end cap, taking care not to damage the cap seal, and tighten the tie rod nuts of the hydraulic cylinder.
- Install the 3-way valves, rated for 150 psi (10.3 bar) working pressure, on the pneumatic cylinder ports (Refer to Figure B) and turn them to venting position.
- Mount the hydraulic pump assembly on the Torque Module's rear accessories pad, as described in previous section.
- Tube the ports of the hydraulic cylinder to the direction control valve's ports, on the hydraulic hand pump unit. (Refer to Figure B) Fill the reservoir with clean hydraulic fluid, till about 1-2" from the top. Fit back the filler-breather cap.
- Turn the direction control valve on the hand pump unit to direct oil flow to one of the cylinder ports. Loosen the corresponding vent plug on the cylinder and stroke the hand pump to vent out air in the lines. Tighten the vent plug when no more air bubbles are seen. Repeat the same for the other side of the cylinder.
- Check and ensure the Hydraulic pressure setting of the pump does not exceed the MOP setting, refer to the table on DA Hydraulic MOP. Use the plugged port on the pressure line Tee to connect a suitable pressure gage. Set the pump relief valve to the MOP, at the stroke end.

MOP for DA Hydraulic Overrides		
Model	MOP	
73 E2	psi	1935
	bar	133
14 E3	psi	2000
	bar	138
24 E3	psi	2090
	bar	144
45 E3	psi	2005
	bar	138
10 E4	psi	2130
	bar	147

15.2.1 Operation – DA Hydraulic Override

1. For Manual Override operation, turn the 3-way valves on the pressure module to vent the cylinder ports to atmosphere and close the hydraulic bypass valve, (HBV). Turn the lever on the direction control valve on the hand pump unit to select the direction of the actuator rotation and stroke the hand pump to reach the required valve position.
2. To restore pneumatic operation, turn the direction control valve to center position, the HBV to Open position and switch the vent valves to connect the cylinder ports to the air supply lines.



CAUTION

Over thrust by the hydraulic override may cause actuator damage. Prevent unsafe conditions and damage by adjusting the overload valve on the pump to limit the hydraulic pressure as per the MOP tables.

15.3 Maintenance of Hydraulic Override

The hydraulic system may require servicing only when testing the system indicates no build up of pressure or the cylinder seals leak.

15.3.1 Spring Return Hydraulic Override Cylinder

Leakage of hydraulic fluid past the piston seal can be a cause for failure to hold the position when operating the override. Leakage can be confirmed if oil can be seen dripping out of the weep hole on the cylinder.

15.3.2 Disassembly of Hydraulic Cylinder

Ensure the hydraulic cylinder seal kit is on hand before disassembling the cylinder.

1. Disconnect the air pressure and the electrical power from the actuator and ensure the actuator turns to the fail safe position.
2. Disconnect the hydraulic tubing from the override cylinder port.
3. Remove the nuts and spring washers from the studs (10) holding the cylinder flange on the Spring Module end.
4. Pull the cylinder out of the Spring Module and inspect for leakage from the weep hole at the rod end. Proceed to replace seals if leakage is confirmed.
5. Secure the cylinder, loosen and remove the rod end guide nut.
6. Pull the piston assembly out of the cylinder.

15.3.3 Servicing Hydraulic Cylinder

1. Remove the old seal and wear rings from the piston and thoroughly clean the cylinder and piston assembly..
2. Replace the u-cup seal and wear ring on the piston with new ones. Lubricate the seal and the wear ring with clean hydraulic fluid and carefully slide the piston into the cylinder.
3. Replace the seals and guide bushing on the rod side nut and install the nut.
4. Flush clean the oil tank and tubing, fill fresh hydraulic fluid and re-mount the cylinder on the Spring module, connect the tubing and vent out the air from the line, as described in the Installation Section.
5. Operate the hydraulic override to test for correct operation.

15.4 DA Override Cylinder

15.4.1 Disassembly of Hydraulic Cylinder

1. Operate the actuator so that the hydraulic cylinder piston is at the cap end side.
2. Shift the direction control valve on the hand pump unit to mid position, disconnect the air pressure and the electrical power from actuator and ensure it stays in this position.
3. Disconnect the hydraulic tubing from the cylinder ports.
4. Remove the tie rod nuts off the hydraulic cylinder and pull the end cap off the barrel.

5. With a socket spanner located on the hex head of the hydraulic cylinder's piston, loosen and disengage the piston rod from the Guide Block in the Torque Module.
6. Remove the fasteners holding the hydraulic cylinder's flange on the Torque Module end.
7. Take the cylinder assembly off the Torque Module.

15.4.2 Servicing Hydraulic Cylinder

1. Drain the oil from the rod side of the cylinder and pull the barrel with the piston and the piston rod out of the cylinder head.
2. Pull the barrel off the piston, remove the old seals and wear band. Thoroughly wash/clean all parts.
3. Inspect the barrel and the piston for any damage or scoring. Repair/replace any damaged parts.
4. Replace the seals, wear rings, guide bushings, o-rings on the cylinder head and end caps. Reassemble the cylinder and install it on the Torque Module as described in the Installation Section.
5. Flush clean the hydraulic fluid reservoir and tubing. Fill fresh fluid to required level before testing the operation of the override as described in installation section.

15.5 Servicing Hand Pump Unit

Refer to the hand pump unit manufacturer's service manual for maintenance instructions.

16.0 JACKSCREW OVERRIDE

Jackscrews provide an economical manual override option on the actuator for use in case of air failure. These jackscrews come in two types, direct hand wheel operated and bevel gearbox driven.

The direct hand wheel jackscrew has a rotating screw threading into a bronze nut when installed on the Torque module of DA actuators and on the Spring module of Spring Return actuators. The hand wheel directly turns the screw or nut to move the jackscrew forward or back.

The bevel gearbox driven jackscrews are required to reduce the manual effort on larger actuator models and stiffer springs that require higher thrust to compress. Here the screw translates with an anti-rotation arrangement.

16.1 Installation

Jackscrew overrides are usually factory installed on the actuator. Override units are shipped with the jackscrew assembly installed on the actuator so that the actuator is ready for installation in the auto operation mode. No additional customer installation is required.

If a field retrofit is required on actuators without a manual override, the installation instructions provide a guide for a qualified technician to install and operate the Jackscrew overrides.

16.1.1 Installing DA Jackscrew Override

1. Disconnect the air pressure and the electrical power from actuator.
2. Remove the DA end cover from the actuator.

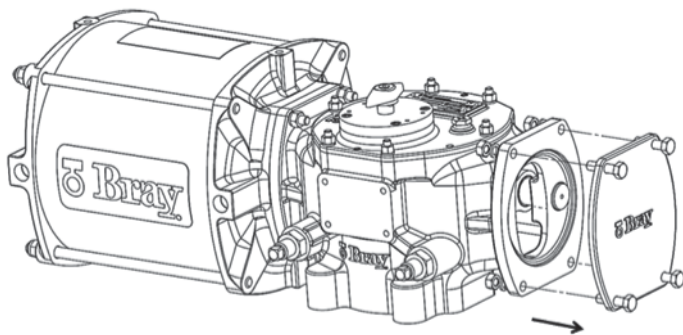

3. Free the Extension Rod from the Jackscrew assembly, apply a drop of medium strength thread lock compound on the extension rod threads and firmly tighten it into the threading in the Guide Block inside the Torque Module. Refer to the piston rod tightening torque table under Section 15.2.

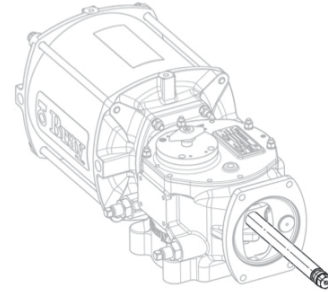

4. Coat the extension rod with NLGI2 grease.
5. Lubricate and place the flange O-ring into the groove on the jackscrew assembly flange

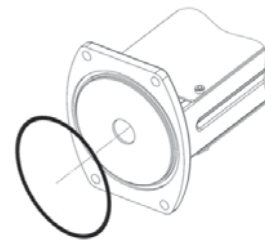

6. Back off the jackscrew fully in the assembly and carefully slide the mounting flange of the jackscrew assembly on the extension rod. Take care in locating the bushing and the flange seal on the extension rod.

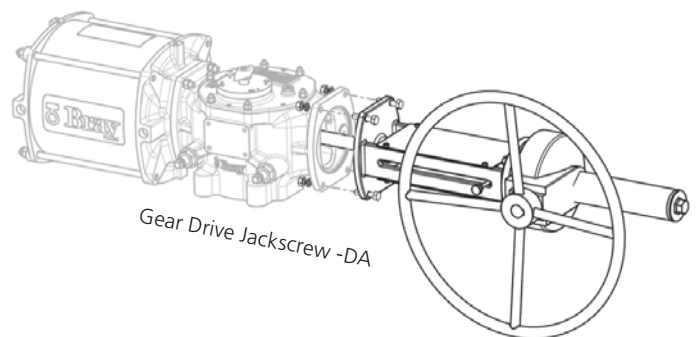
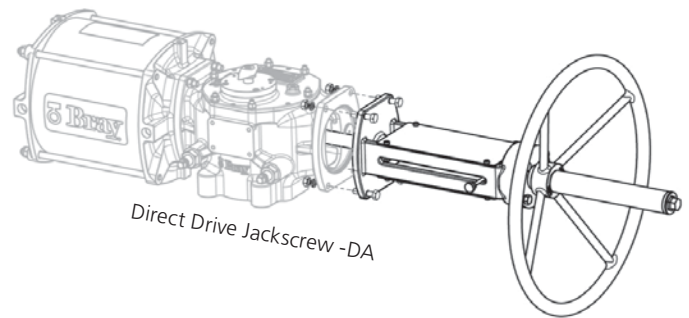

7. Slide the assembly to locate and mate the flanges. Use the hardware supplied in the kit to fasten the assembly to the Torque Module flange.
8. Install suitable size 3/2 manual valves on the pneumatic cylinder's ports, which will either connect the ports to the air supply or vent them to atmosphere. The ports must be vented when operating the manual override (Refer to Figure C).
2. Turn the hand wheel on the jackscrew assembly to move the screw forward, until it touches the extension rod's end.
3. Push the T-handle into the jackscrew head to couple it with the extension rod.
4. Turn the hand wheel to turn the actuator in required direction (see direction markers on the hand wheel).
5. After completing the manual override stroke, disengage the coupler by pulling out the T-handle. Back off the jackscrew completely before restoring pneumatic operation.

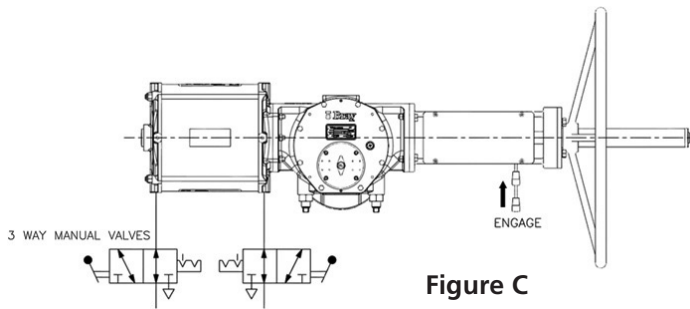

16.1.2 Operating DA Jackscrew Override

1. To test / operate the override, shut off the main air supply and turn the 3 position valves on the cylinder ports to vent the ports to atmosphere.

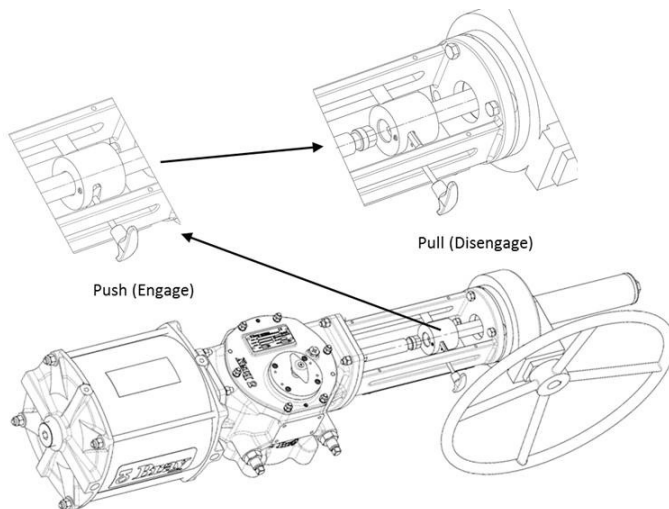

NOTICE

The jackscrew is not designed as an extended travel stop. It must be taken to fully backed-off position for the actuator to work normally in automatic mode. Turn the 3 position valves to connect the air supply to restore automatic operation.

CAUTION

The extension rod moves back and forth in normal operation. Do not remove any protective covers on the DA jackscrew assembly without ensuring the air supply is cut off and that the automatic operation of actuator is disabled.

16.2 Installing SR Jackscrew Override

1. Disconnect the air pressure and the electrical power from actuator and ensure the actuator is at its fail safe position.
2. Remove the end cover on the Spring module. Retain/replace the cover O-ring.

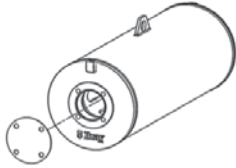

3. Apply a drop of thread lock compound on the mounting stud threads and firmly tighten them into the spring module end cap.



4. Back off the jackscrew fully in the assembly and mount the jackscrew assembly on the spring module end cap thrust base.

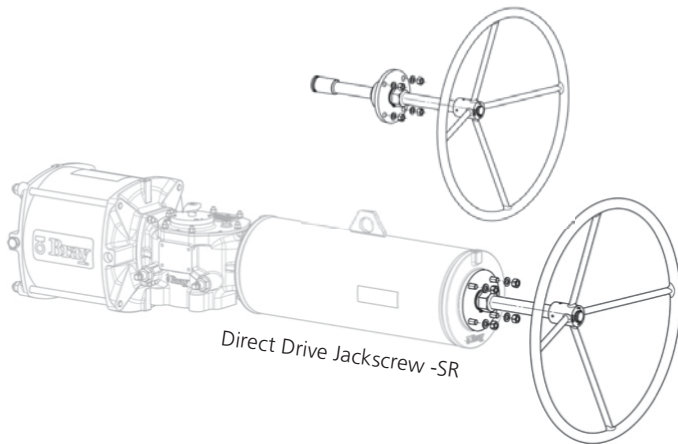

5. Locate the Jackscrew assembly flange into the studs and fasten with the supplied nuts and lock washers.

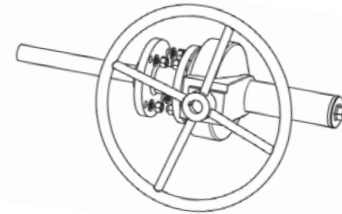

6. Install a suitable 3 position manual valve to the pneumatic cylinder's rod end port (Refer to Figure D).

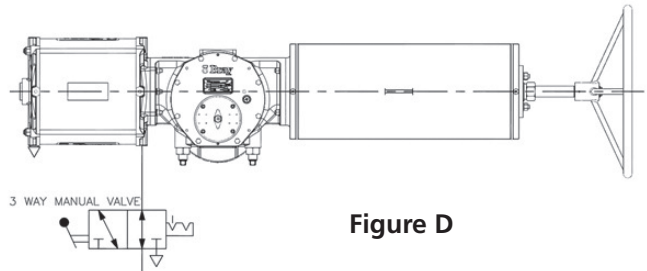

Figure D

16.2.1 Operating SR Jackscrew Override

1. To test / operate the override, shut off the main air supply and turn the 3 position valve on the cylinder port to vent the cylinder port to atmosphere. The actuator should move to its fail safe position.
2. Turn the hand wheel on the jackscrew to advance the screw into the spring module (see direction markers on the hand wheel).
3. Resistance will be felt when the thrust head of the jackscrew touches the end of the spring rod.
4. Turning the hand wheel further will compress the spring and simultaneously turn the actuator.

NOTICE

The spring constantly loads on the jackscrew and returns the actuator to fail safe state when the jackscrew is retracted. Bring the actuator to fail safe position and turn the 3 position valve on cylinder port to connect to air supply to restore auto operation mode.

CAUTION

Never disassemble the Jackscrew assembly with the spring load on the screw. Severe injuries/damage can result due to non-compliance.

Retract the jackscrew completely to free the load, before attempting any maintenance on the assembly.

17.0 EXTENDED STOPPERS

Extended Stoppers allow restriction of the actuator rotation angle higher than the travel stops provided on the Torque Module. These Extended Stoppers modules fit on the Torque Module for single cylinder double acting actuators and on the Spring Module for the spring return actuators.

The standard extended stops restrict the linear stroke of the Guide Block to provide the rotation adjustment up to 45 degrees from the end. A 90 degree extended stop is an option.

17.1 Installation

Extended Stoppers are usually factory installed on the actuator and adjusted to the angle per customer's requirement if supplied as a valve-actuator package. If supplied as fitted on stand-alone actuator then the stoppers are backed off fully, to permit installation at site on the valve and they must be adjusted after installation.

If a field retrofit is required on actuators without the extended stopper, the installation instructions provide a guide for a qualified technician to install and adjust them.

17.1.1 Installing Extended Stopper for Torque Module

This Extended Stopper module is installed only on Single Cylinder DA actuators.

1. Disconnect the air pressure and the electrical power from actuator.
2. Remove the DA end cover from the actuator.

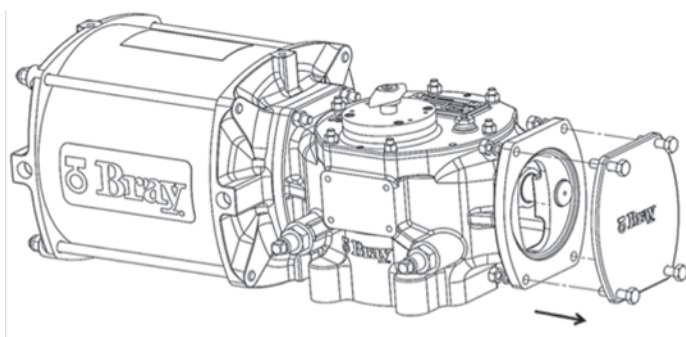

3. Clean threads on the Guide Block.

4. Apply medium strength thread lock compound to the threads of the Bolt (4) and thread it into the Guide Block and tighten to lock the Bolt on the Guide Block face.

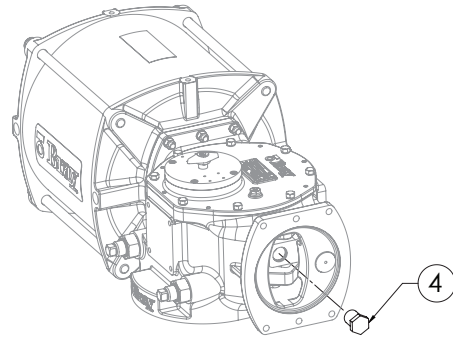

5. Loosen the Lock Nut and back off the Extended Stopper in the assembly.
6. Lubricate and locate the flange O-ring in the groove on the assembly's flange and mount the assembly on the torque module.

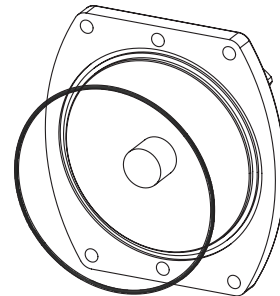

7. Secure the assembly with the mounting bolts, nuts and lock washers from the mounting kit.

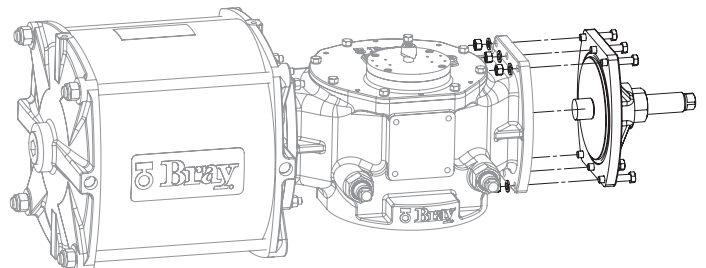

17.1.2 Adjusting Extended Stopper

Connect air supply to the rod end side port of the pneumatic cylinder, adjust the extended stopper screw to required position, and reverse the actuator direction to stop movement by the extended stopper. Confirm position and tighten the seal-nut to lock the position.

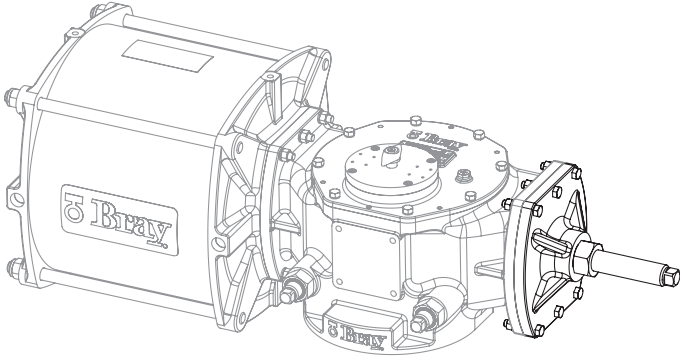

NOTICE

The Extended Stopper is not designed as a jackscrew. Do not use this to manually override the actuator. Always adjust the stopper with no load on it.



WARNING

Never remove the assembly fasteners without first backing off the Extended Stopper fully to release any load on it.

17.2 Installing Extended Stopper for Spring Module

This Extended Stopper module is installed on Spring Module's thrust base.

1. Disconnect air pressure and any electrical power from actuator.
2. Remove the end cover on the Spring Module.
3. Thread in and tighten the studs from the mounting kit, into the Spring Module thrust base. Use thread lock (Loctite 242 or equivalent). Locate the end cover O-ring in the groove.
4. Back off the stopper bolt and mount the Extended Stopper assembly on the Spring Module end cap.

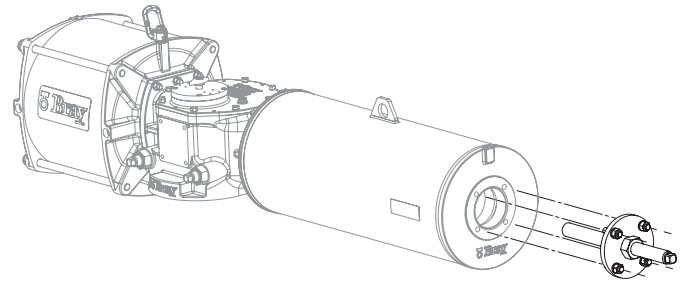

5. Tighten the nuts with spring washers; refer to Table 10.4 for tightening torque for the nut size.

17.2.1 Adjusting Extended Stopper

1. Connect air supply to the rod end side (Adaptor) port of the pneumatic cylinder; tighten the extended stopper screw to approximately required position. Release air so that the actuator will reverse direction by the spring action and stop against the extended stopper. Repeat to get to final position.
2. Confirm position and tighten the seal-nut to lock the position.

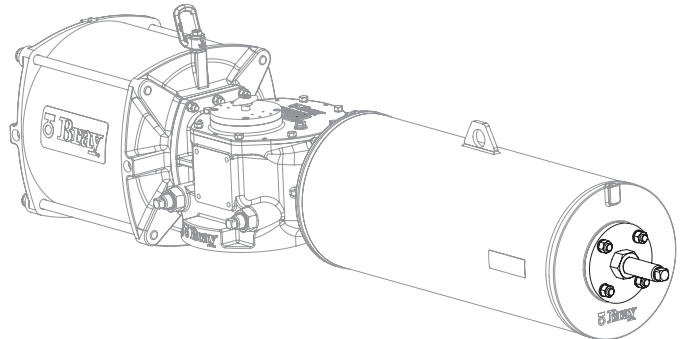

NOTICE

The Extended Stopper is not designed as a jackscrew. Do not use this to manually override the actuator. Always adjust the stopper with no load on it.



WARNING

Never remove the assembly fasteners without first backing off the Extended Stopper fully to release any load on it.

18.0 HYDRAULIC DAMPER

Hydraulic Damper is typically used on a spring return actuator in a fast stroking application, to slow down the end of the spring stroke. These are modular in construction and can be added on to the S98 standard actuator, without any modifications to the basic actuator.

The dampers reduce the speed at the end of travel so as to avoid the valve disc slamming and the impact damages to the actuator that may otherwise result. These dampers reduce the linear speed of the actuator's members when the damper comes into action, set for approximately the last 15 to 20 degrees of the rotation. The damper module is mounted on End Cap of the Spring Module.

The Hydraulic Damper assembly consists of the damper unit, the damper housing, lock nut, O-ring seal, End cover and the mounting fasteners.

18.1 Assembling the SR Hydraulic Damper Module

18.1.1 Thread in the hydraulic damper (threaded body type units) into the damper housing, as in the below image.

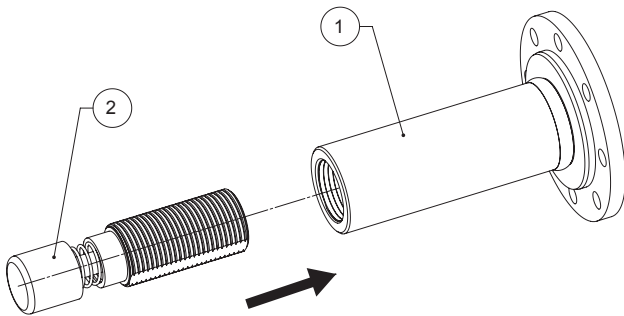

18.1.2 Refer to the table below and set the assembly default length 'L' from the back face of the mounting flange.

Model	Hydraulic Damper	'L' (mm)
45 E2	98-S04D-22907-XXX	330
73 E2	98-S04E-22907-XXX	330
14 E3	98-S05F-22907-XXX	429
24 E3	98-S02G-22907-XXX	412
	98-S05G-22907-XXX	
45 E3	98-S02H-22907-XXX	470

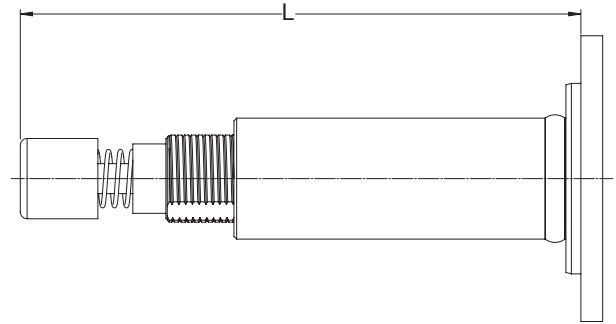

18.1.3 Thread in the lock nut (3) and jam it on the housing face to lock the damper on the housing (1).

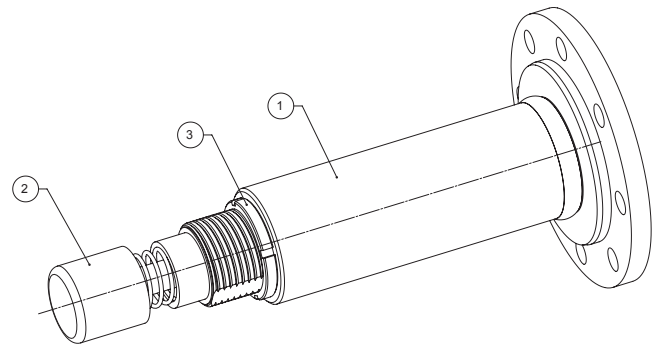

18.1.4 For the damper units without the threaded body (typically for models 24E3 and above), insert and thread in fully the piston side of the damper unit into the sleeve housing (11) and lock them with the set screw (13).

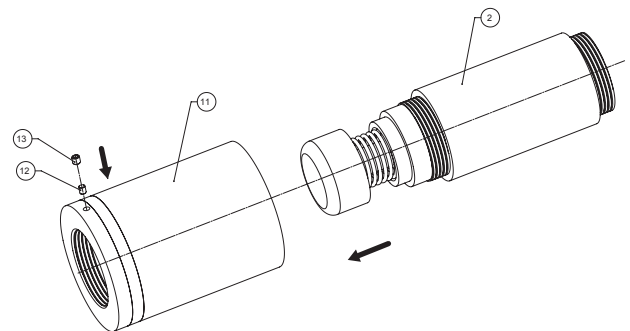

18.1.5 Thread the sleeve on the damper housing (1), set the length 'L' and lock the assembly with the locknut (3).

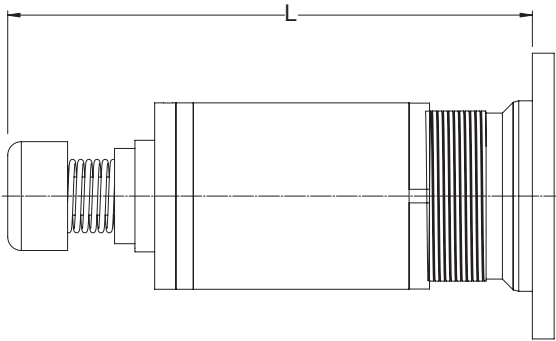
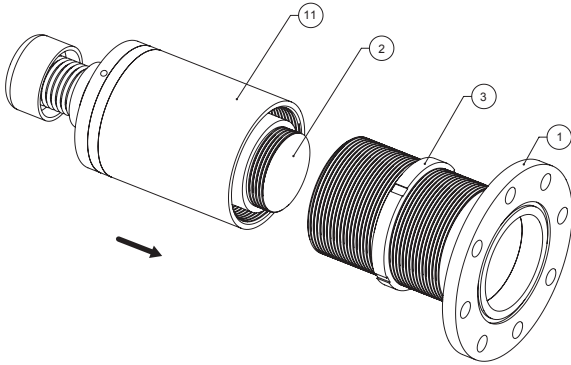

18.1.6 Lubricate and install the O-ring in the groove, fit the end cover on to the housing with bolts and paste the sticker on the end cover.

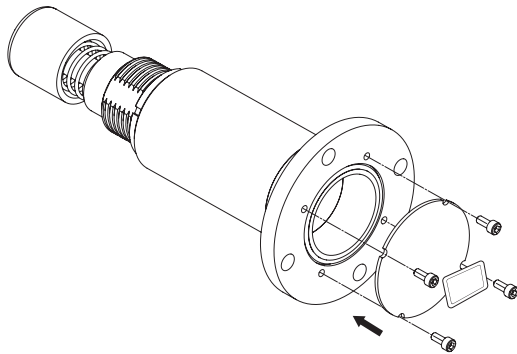

18.2 Installing the SR Hydraulic Damper Module on S98 actuator

Note: The damper module installation and adjustment shall be carried out after the valve-actuator assembly has been first set for proper seating of valve disc (closure element) by the actuator's travel stops.

In case of a stand- alone actuator having been supplied with a hydraulic damper module pre-installed, the damper must be adjusted per below procedure after the actuator is installed on the valve.

18.2.1 Depressurize the actuator and remove the end cover (55) by unfastening the bolts (58). Retain the O-ring (59) in the end cap groove.

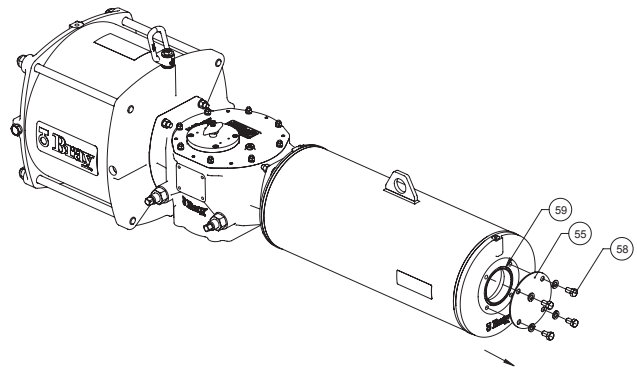

18.2.2 Remove Damper end cover from its housing.

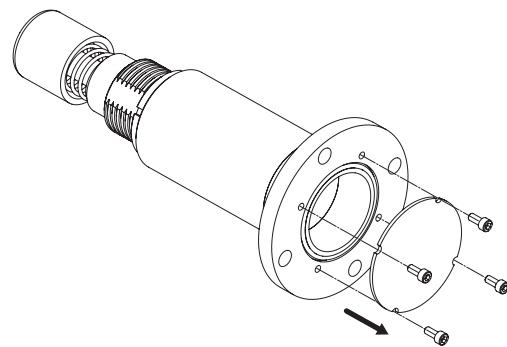

18.2.3 With an extended hex wrench (Allen key), turn the damper rate adjustment screw at the base of the damper unit to the minimum setting. At this setting it would be possible to press the damper piston by hand, against the return spring.

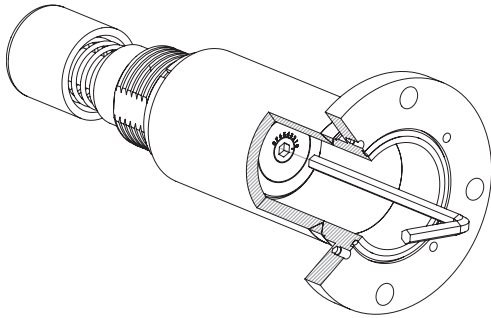

18.2.4 Ensure the actuator's travel stops have been set & locked for proper valve seating (closed) position.

18.2.5 Measure the distance "X" from the spring module's end cap machined face to the spring rod's face.

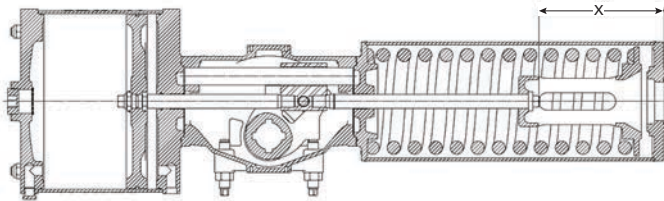

18.2.6 This length shall not be less than the solid length of the damper assembly. The hydraulic dampers normally used on the S98 have a 50mm max. stroke, but about 40mm of this is used for dampening. Use the below guide to check and reset the assembly length "L" of the damper module.

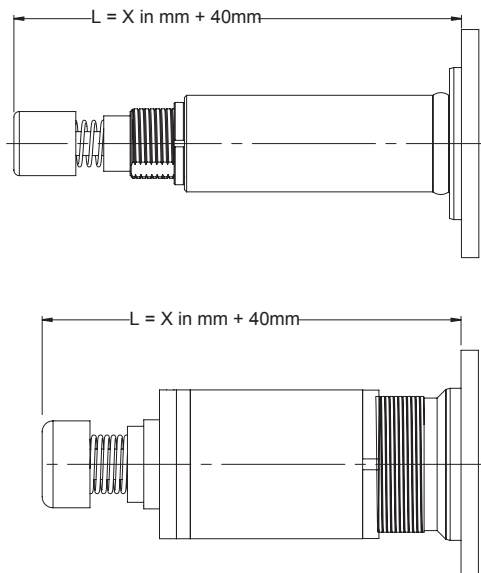

18.2.7 Tighten the locknut to secure the damper unit to the damper housing.

18.2.8 Apply a drop of thread lock compound and thread in the studs (8) from the kit into the end cap.

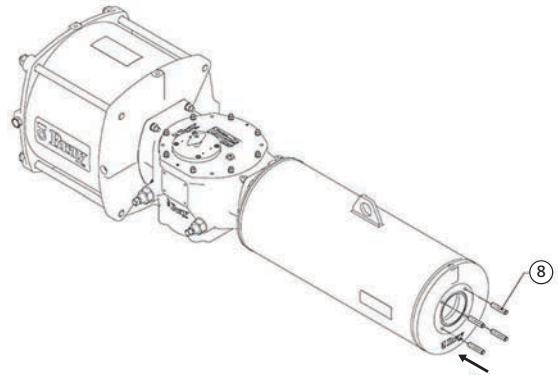

18.2.9 Insert the damper assembly into the spring module, locating the flange through the studs. Press the flange to mate the inside face on the flange to the spring module's end cap and secure the assembly with the spring washers and nuts. Tighten the nuts, refer to table under Section 2.1.5 for bolt torque values.

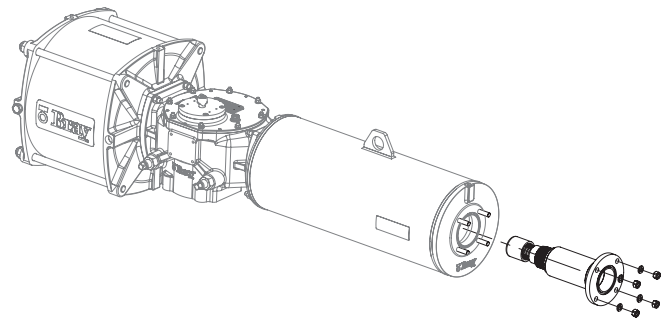

18.2.10 With an extended hex wrench adjust the damper setting screw to about two settings below the maximum.

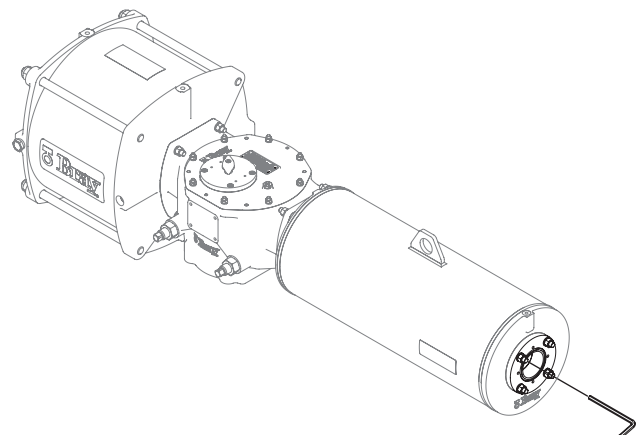

18.2.11 Operate the actuator by pneumatic pressure to full stroke and release the air pressure. Observe the valve disc for the dampening rate and adjust the damper screw to higher or lower setting, as required.

18.2.12 Lubricate and insert the supplied O-ring in the groove on the outside of the damper housing flange.

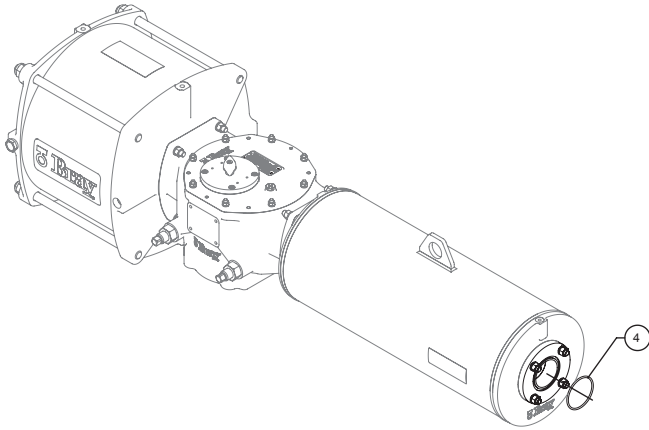

18.2.13 Fix back the damper end cover with screws.

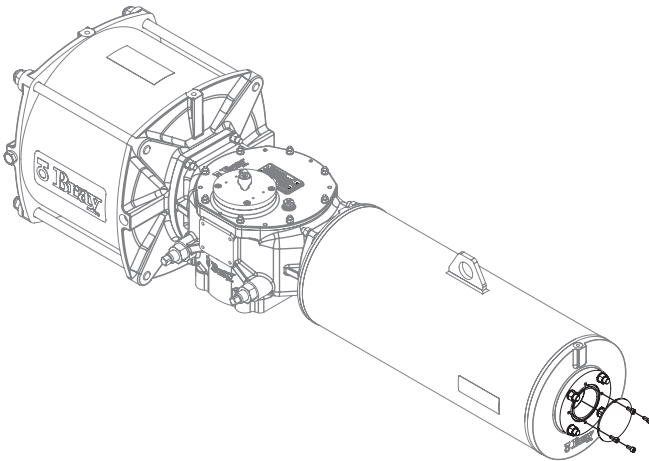

REFERENCE DRAWINGS

Description	Drg #
Hydraulic Override Assembly DA	ES 00094
Hydraulic Override Assembly SR	ES 00095
Jackscrew Assembly, DA Direct Drive	ES 00105
Jackscrew Assembly, DA Gear Drive	ES 00106
Jackscrew Assembly, SR Direct	ES 00113
Jackscrew Assembly, SR Gear Drive	ES 00114
Sandwich Gearbox	ES 00126
Extended Stoppers, SR	ES 00127
Extended Stoppers, DA	ES 00201
Hydraulic Damper	ES 00443

TROUBLE SHOOTING POTENTIAL PROBLEMS

FAULT	POSSIBLE CAUSES	RECOMMENDED ACTIONS
Erratic Movement	Inconsistent supply /dirty operating media/clogged filters	Check media supply pressure and line filters, correct as necessary. Refer to Introduction section in this manual for operating media requirements.
	Inadequate lubrication	Disassemble and lubricate. Refer to Maintenance section in this manual for lubricant specs.
	Worn/damaged parts	Disassemble and inspect. Replace worn/damaged parts. Refer to Disassembly, Service & Reassembly of Modules section in this manual.
	Seal set due to long periods of inactivity	Operate for 5-10 cycles and check. Replace seals if not resolved. Refer to the procedures under Pressure Module section in this manual, for replacement and testing procedures.
	Valve problem - bearing/seal friction, damaged parts	Refer to valve manufacturer's IOM.
Incomplete Stroke	Stoppers set incorrectly	Check and adjust.
	Foreign object left inside during maintenance	Disassemble, inspect for damages and correct.
	Manual override in wrong position	Check and fully retract manual override devices for proper automatic operation.
	Valve problem - Restriction, friction, incorrect valve stopper	Refer to valve manufacturer's IOM.
Loss of power	Supply pressure inadequate	Check and correct supply pressure to operating pressure.
	Inadequate flow	Check flow control devices and adjust for sufficient flow. Repair any kinked tubing.
	Tubing or exhaust vents blocked	Check and clean the vents, silencers and tubing.
	Pressure Module seals leaking	Check leaks and replace seals. Refer to the procedures under Pressure Module section in this manual, for replacement and testing procedures.
	Defective Accessories/Inadequate capacity	Refer to accessory manufacturer's IOM manual and specs.
	Valve jammed or requires higher torque	Refer to valve manufacturer's IOM.
No response to energizing	Altered schematic	Check if the control circuit is as per the supplied schematic. Correct the circuit, if altered.
	Solenoid valve/positioner/control elements malfunction	Check /Refer to accessory manufacturer's IOM manual for troubleshooting.
	Disengaged piston rod/ broken connection/ jammed mechanism	Refer to Maintenance section for module/actuator disassembly procedures to disassemble appropriate module for inspection.
	Valve problem - jammed	Refer to valve manufacturer's IOM.
Fails to go to the failsafe position	Altered schematics	Check if the control circuit is as per the supplied schematic. Correct the circuit, if altered.
	Control component malfunction/failure	Check and replace
	Choked exhaust silencer/foreign object blocking exhaust line	Remove vent to confirm normal operation. Clean/replace exhaust silencer.
	Spring rod disengaged/connection broken	Refer to Maintenance section for module/actuator disassembly procedures to disassemble appropriate module for inspection.
	Valve problem - jammed	Refer to valve manufacturer's IOM.

POTENTIAL MISUSE	PREVENTION MEASURES
Use in unintended conditions	Refer to Introduction & Installation sections in this manual and supporting product documentation. If in doubt, contact manufacturer.
Supply pressure greater than the actuator MOP to compensate for valve problems / incorrect selection.	Use of appropriate pressure limiting devices in the supply pressure line to limit the pressure to actuator's MOP is highly recommended and shall be ensured by the end user. Refer to the Maximum Operating Pressure sections in this manual. Actuator MOP is printed on the name plate for ready reference.
Actuator subjected to temperatures out of permissible limits	Refer to name plate and to General Specifications section for the limits of service temperature of the supplied trim. Ensuring the environmental conditions do not cause over the limit temperatures, is end user's responsibility.
Used with operating media that does not conform to specification	Clean dry media of instrumentation grade only shall be supplied. Refer to Introduction section of this manual for specs.
Lifting actuator-valve-accessories assembly using lifting lugs on actuator that are meant only for the actuator	Read Warnings in the Installation section of this manual and on the stickers pasted on actuators. Use slings and tackles of sufficient capacity appropriately for lifting assemblies. Actuator weight is printed on the name plate for ready reference.
Pressurizing cap end port on spring return actuators to overcome valve jamming or to compensate valve sealing problems	Refer to Operation Guidelines section of this manual. Pressurizing pneumatic cylinder to aid spring may cause over load on valve stem and actuator parts resulting in damages to valve/ actuator. Do not substitute the vent provided on cap end port of cylinder with a pipe fitting.
Maintenance by unauthorized personnel	See Safety Information section. Do not permit anyone, other than qualified technicians who have read and fully understood the installation and maintenance instructions, to perform any maintenance/adjustments on the actuator.
Maintenance without de-energizing	Refer to Disassembly, Service & Reassembly of Modules section of this manual. Under no circumstances shall attempt be made to disassemble the pressure module or any fastener/ plug be loosened, without isolating supply pressure and venting the cylinder ports to atmosphere.
Operating the actuator without end covers	Never operate the actuator in partially disassembled condition or with the Spring Module / Pressure Module end plate removed.
Altering the design to increase spring end load for compensating valve seating problems	Strictly prohibit change of any component design or adding spacers to increase the spring end load. The Spring Rod thread engagement will be compromised and this can have disastrous consequences resulting in equipment damage and/or severe personal injury.

RESIDUAL RISKS
This document does not cover every detail about every version of the product described. It cannot take into account every potential occurrence in installation, operation, maintenance and use.
End user shall devise and provide adequate protection against hazards such as:
External Fire
Impacts during installation/servicing
Hazardous emissions when Natural Gas is operating media
Contact with metal surfaces due to high/low ambient temperatures or conduction/ radiation
Static electricity.